



Smart Growth Committee Meeting  
**July 9, 2025 @ 6:30 PM**  
*This meeting is recorded for public record.*

**Committee Members:**

Nicole Scimone, Chair  
Lisa Dorsey  
Bernie Flynn

**Smart Growth Committee of Borough Council:**

**Borough Manager:** Sean Metrick

---

**Smart Growth Committee Meeting:**

1. Call to Order
2. Announcements
3. Comments  
Comments, suggestions, petitions by residents in attendance regarding items that are not on the agenda. Please be advised that all public comment has a 5-minute time limit.
4. Reports
  - A. Director's Report
5. Old Business
  - A. Motion to approve Smart Growth Committee minutes – June 11, 2025
6. New Business
  - A. Motion to approve HARB applications (attachment)*Issue: Consider a Motion to approve the June HARB Certificate of Appropriateness*
    1. 2025-18: 120 N. Church St-Exterior mechanical equipment installation
    2. 2025-19: 233 W. Gay St-Exterior mechanical equipment-Rectory office
    3. 2025-20: 233 W. Gay St-Exterior mechanical equipment-Choir mezzanine
    4. 2025-21: 202 W. Gay St-Replace front door and sign
  - B. Consider directing the Solicitor to attend Zoning Hearing Board (attachment)
    1. 531 Marshall Drive: relief from residential dimensional and parking requirements
    2. 501 E. Miner St: relief to allow illuminated ground mount sign at The Melton Center on West Market Street.

- C. Discuss amendment to front yard setbacks of the Zoning code.
- D. Discuss revisions to café permits, dining platforms in parking areas, and use of the street during Gay St closure.  
*Issue: Improvements to regulations for outdoor seating standards and possible ordinance updates.*
- E. Motion to grant extension until August 31, 2025 for 210-214 W Washington Street, Axel Square land development project.

7. Other Business

8. Adjournment

Visit [www.west-chester.com](http://www.west-chester.com) for access to all attachments.

Agendas are posted to [www.west-chester.com](http://www.west-chester.com) by noon 3 business days prior to the meeting.



## Borough of West Chester

401 East Gay St West Chester PA 19382

### **Borough Council**

Patrick McCoy, President  
Nicole Scimone, Vice President  
Bryan Travis  
Brian McGinnis  
Sheila Vaccaro  
Bernie Flynn  
Lisa Dorsey

### **Mayor**

Lillian L. DeBaptiste

### **Borough Manager**

Sean Metrick

Department of Building and Housing Monthly Report – June 2025

To: Smart Growth Committee of Borough Council

From: Ramsey Reiner, Interim Director of Building and Housing

July 9<sup>th</sup>, 2025

### **Summary Highlights**

- We have made an offer to a candidate and are going through the hiring process with a tentative start date of July 21.
- We held a Landlord Open House on June 2<sup>nd</sup> to go over the portal, Chapter 66 and rental license requirements. There were around 15 attendees.
- Rental license renewal period continued for 2025-2026. We have been contacting all property owners/managers that have outstanding required submittals and will not be depositing checks and issuing licenses until items are complete.
- Holds have been placed on all properties that have outstanding balances for the Borough, including taxes and sewer. No permits or licenses will be issued until these are paid. Property owners must contact Portnoff directly. Portnoff Law Associates, Ltd. 866-211-9466  
<https://www.portnoffonline.com/contact/>

### **Planning & Zoning**

- 250 E Market Street: Project has preliminary final approval and has submitted updated plans to be reviewed.
- 7 N Adams: Has been granted a special exception by ZHB. Nothing new at this time.
- 210-214 W Washington: is considering revising the number of units. Requesting an extension until August 31.

### **Codes Enforcement**

- Code officers have continued to inspect rental properties.
- There will be a small lull in trash enforcement tickets as there was an ordinance update, which requires updates to our software system.

**Code Enforcement Tickets Issued: Grass, Snow & Trash**

Status	24-Oct	24-Nov	24-Dec	25-Jan	25-Feb	25-Mar	Apr-25	May-25	Jun-25
Paid			2	61	43	44	74	68	11
Issued			1	2		27	0	9	8
Warning	2	2		2	3	8	18	38	9
Void					3	6	5	2	3
Dismissed				4	12	2	10	10	3
Abandoned				1		2	0	1	
In Dispute						1	1	0	3
Court	0	0	0	20	11	1	16	12	0
	2	2	3	90	72	91	124	140	37

**Rental Licensing**

Rentals	<u>Feb</u>	<u>Mar</u>	<u>Apr</u>	<u>May</u>	<u>Jun</u>
Annual Rental Inspection	111	127	129	128	165
Initial Rental Inspection (New Rental)	3	5	5	3	1

- We received checks for 670 rental licenses. We have cashed 163 checks in the amount of \$29,096 (as of July 2<sup>nd</sup>) for approved rental licenses.

<u>Status</u>	<u>June 2025</u>
Pending	285
Approved for payment	31
Issued	345
Incomplete	177
Not renewed	68
Total	906

**Points**

- No points accumulated in June because no active citation was found guilty in that month. There were no PD citations received this month. The points reset on July 1<sup>st</sup>.

## Building Permits

		Feb	Mar	Apr	May	Jun
<b><u>Code Enforcement</u></b>						
Enforcement Requests		40	71	34	84	53
Cases Opened		21	49	15	54	24
Cases Closed		23	28	55	71	50
<b><u>Permits Issued</u></b>						
CERTIFICATE OF OCCUPANCY		2		1		
COMMERCIAL ADDITION-ALTERATION-REPAIR		4		10	6	8
RESIDENTIAL ADDITION-ALTERATION-REPAIR		18		25	51	19
RESIDENTIAL DEMOLITION		1				1
COMMERCIAL DEMOLITION					1	
CAFE PERMIT CONTRACT				15	7	
HOME OCCUPATION				1		
SIGN PERMIT				2		2
RESIDENTIAL NEW BUILDING				2		
CERTIFICATE OF APPROPRIATENESS-SIGNS					1	1
ZONING SITE PLAN REVIEW					4	1
<b><u>Permit Applications Received</u></b>						
CAFE PERMIT CONTRACT		6	14	28	7	1
CERTIFICATE OF APPROPRIATENESS- SIGNS		1	1	4	2	1
CERTIFICATE OF APPROPRIATENESS- REPAIR					5	1
CERTIFICATE OF OCCUPANCY		3	2	2	2	1
COMMERCIAL ADDITION-ALTERATION-REPAIR		8	4	18	14	10
COMMERCIAL DEMOLITION					1	
LAND DEVELOPMENT APPLICATION			1	1		1
HEN PERMIT		1			1	1
RESIDENTIAL ADDITION-ALTERATION-REPAIR		41	42	53	60	22
RESIDENTIAL DEMOLITION						3
RESIDENTIAL NEW BUILDING		4	2	2	1	
SIGN PERMIT		3	4	3	5	2

VARIANCE/SPECIAL EXCEPTION, ZONING APPEAL		1	2	1		1
ZONING SITE PLAN REVIEW		7	13	8	4	1
ZONING VERIFICATION LETTER			1	1	1	1
<b><u>Building Permit Inspections</u></b>		30	85	164	100	99
<b><u>Code Enforcement</u></b>						
NUISANCE			1		4	
PROPERTY MAINTENANCE		23	33	2	49	10
RIGHT OF WAY		1				
ZONING VIOLATION		1	4	1	1	1
BUILDING CODE VIOLATION					2	1

# Rental Enforcement Activity



**DEPARTMENT OF BUILDING,  
HOUSING, AND CODES  
ENFORCEMENT**



July 1, 2024 to June 30, 2025

# Citations Issued by WCPD and DBnH

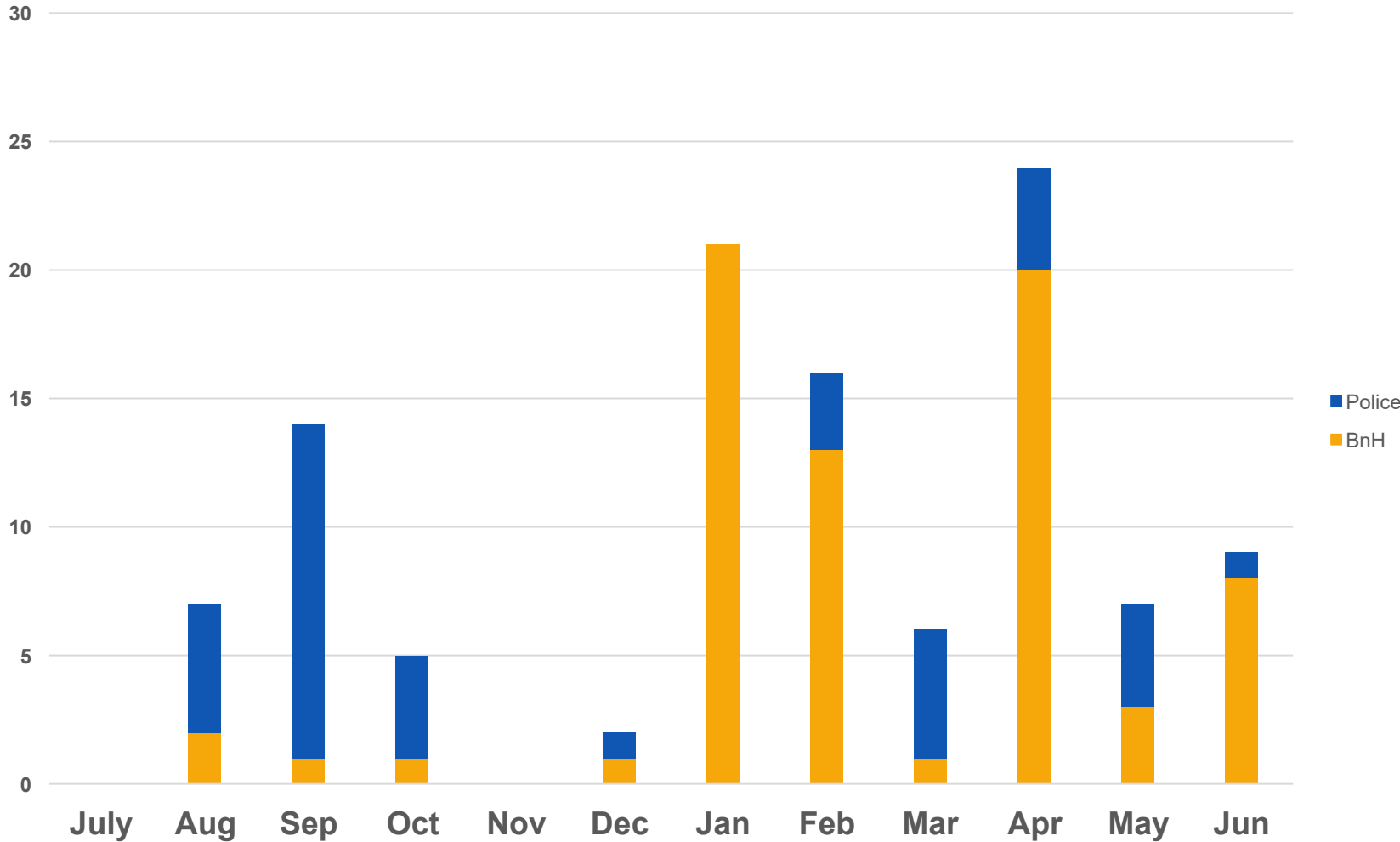

Notices/ Tickets



Citations/ Court



Points/Consequence

111 total  
71 DBnH  
40 WCPD



# Rentals v Owners

Is it a Rental?

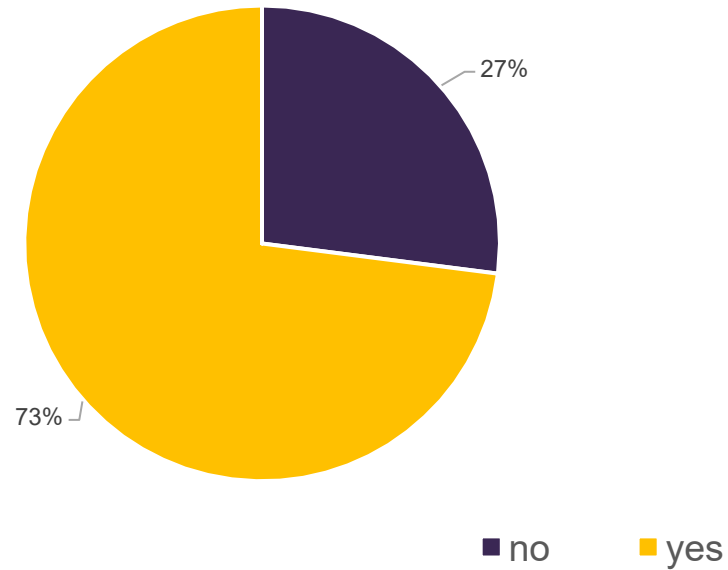

30 Citations against owner occupied properties  
81 Citations against rental properties

# Violation types

Count of Infraction type

Types of Citations- All

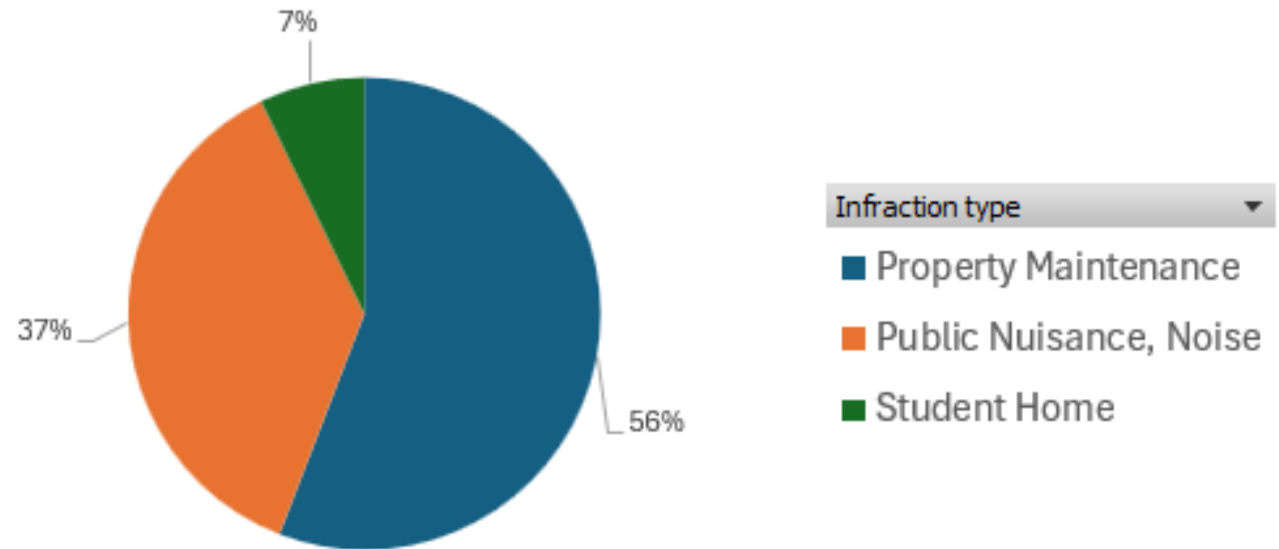

# Success Rate in Court

## Disposition of Closed Cases

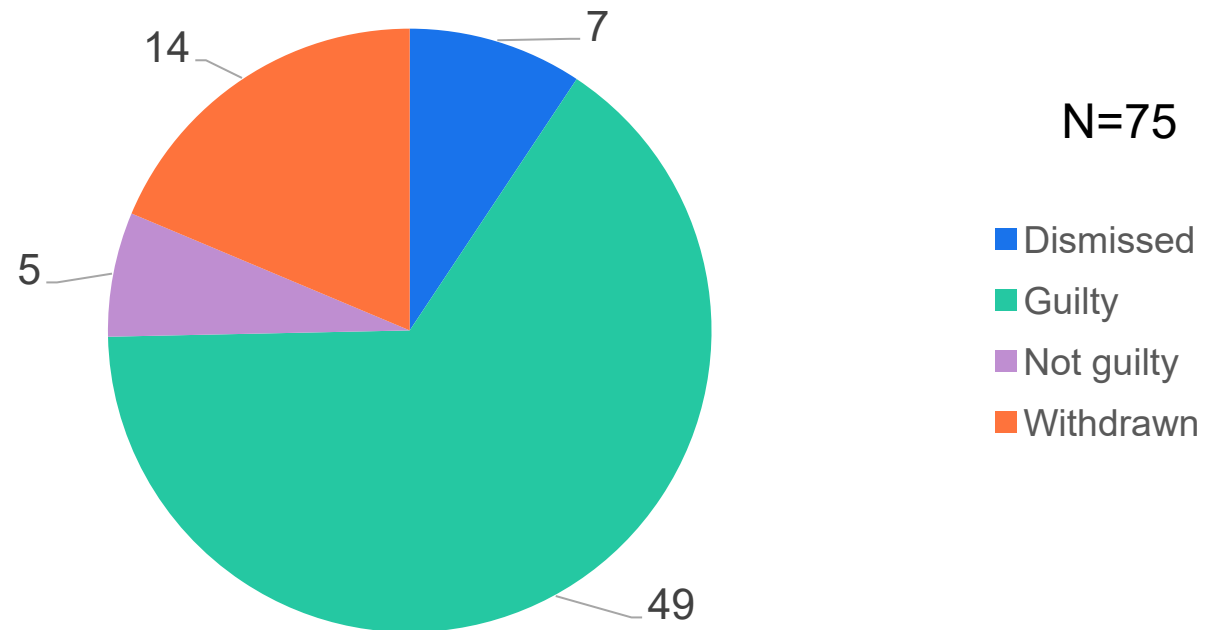

5 inactive cases  
25 cases pending  
6 cases not found in UJS

# Points Accumulated

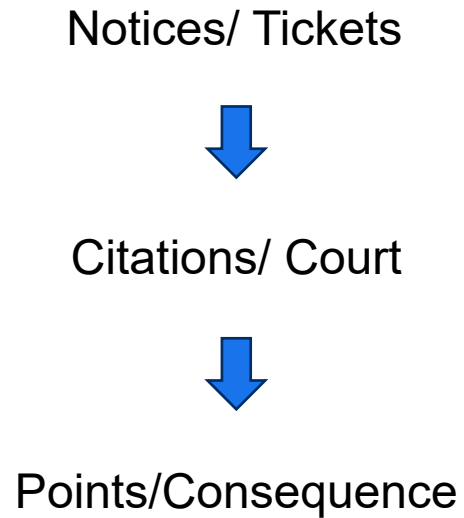

Points by Property Frequency Distribution

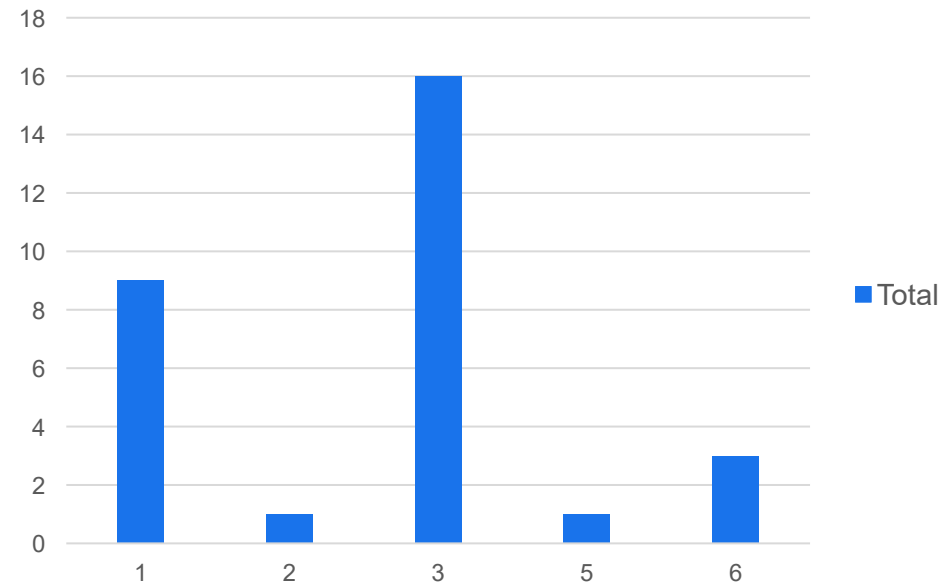

Row Labels	Sum of pts
248 E. Gay St	6
315 S. High St	6
500 S. Walnut St	6
21 W Barnard St	5
211 S. Walnut St	3
217 S. Walnut st	3
419 S. Walnut St	3
429 S. Walnut St	3
432 S. Walnut St	3
437 S. High St	3
439 S. High St	3
443 S. High St	3
501 S. Walnut St	3
507 S. Walnut St	3
511 S. High St	3
526 S. Walnut St	3
626 S. High St	3
628 S. Walnut St	3
633 S. Walnut St	3
750 S. Franklin St	3
608 S. Walnut St	2
128 Magnolia St	1
134 Lacey St	1
217 s walnut	1
501 s matlack	1
508 S. High St	1
512 S Franklin	1
520 s matlack	1
605 s walnut	1
701 S Walnut	1
	82



# Recommendations

- Consistent performance is necessary for the system to work as intended
  - Training, reporting, practice, accountability of enforcement.
- WCPD and BnH integration is performing well
- Review cases dismissed, not guilty, or withdrawn. Identify gaps
- Option - Investigate extending period of point accumulation

## DRAFT MEETING MINUTES

### SMART GROWTH COMMITTEE OF BOROUGH COUNCIL

Date: Wednesday, June 11, 2025 @ 6:30 PM

Committee Members: Nicole Scimone, Chair  
Lisa Dorsey  
Bernie Flynn

Staff: Ramsey Reiner, Interim Director of Building, Housing & Code Enforcement Sean Metrick, Borough Manager

I. Call to order 7:00PM

II. Announcements

- A. Ms. Scimone announced a public hearing June 18, 2025 at 6:30 pm: Amending the Code of the Borough of West Chester, Chapter 54, titled Electrical Standards, Chapter 72, titled Mechanical Standards, and Chapter 82, titled Plumbing, by amending the licensing requirements for contractors performing work in the Borough of West Chester.

III. Comments, suggestions, petitions by residents in attendance regarding items not on the agenda. *(Please be advised that all public comments have a 5-minute time limit.)-None*

IV. Reports

- A. Director's report-Interim Director Ramsey Reiner provides monthly update for May 2025. Ms. Scimone compliments Director Reiner on the excellent work she has done, bringing the department in line. Mr. Flynn asks about rental license procedures with checks mailed to the office and old Tenant Landlord forms. Director Reiner answers by telling the Committee there is a spreadsheet with all the checks that are mailed to the office, the license is checked in the software to see if the property owner has a portal account, and what may be outstanding with required form and inspection. The property owner is contacted with these items; checks are held until all outstanding items are satisfied. If no contact can be made, the check will be mailed back with communication on how to set up the portal account and proceed accordingly.
- B. Presentation by Safe Harbor of Chester County, 20 N Matlack St (attachment)  
*Issue: Discussion of current facilities and services and future plans-* Jessica Chapel, Director of Safe Harbor presents the current facility and services at Safe Harbor. Starting in 1994, Safe Harbor is the largest homeless shelter for single adults in Chester County, 150 plus residents annually, 43,000 meals served annually and 233 volunteers in 2024. Safe Harbor is rapidly evolving from a shelter to a whole person service provider to end homelessness by providing life skills training. With a growing need and limited space, there is vision of expansion to building a three-story facility in the parking lot next to the current facility. This will expand the housing portion of Safe Harbor by 50 percent. Ruby Aberera, Senior Director of Finance and Growth, details the expansion plan with ground floor will retain parking; first floor will contain seven flexible housing units for 24 people. Second floor will contain 64 beds in four wings of 16 and the rooftop will have a garden and solar panel for wellness & sustainability. This project would cost approximately \$5 million dollars and is asking the Borough to provide a letter of support to move forward with grant writing and planning. Mr. Flynn recommended Safe Harbor contact Pennrose Management that presented almost the exact same proposal last year and they just opened a facility in Chinatown neighborhood Philadelphia. Smart Growth agrees to provide draft letter. Mr. Metrick asked Ms. Chapel to draft a letter and forward to the Borough for signature.

V. Old Business

- A. Motion to approve Smart Growth Committee minutes – May, 2025- 3:0 Recommend motion approval

VI. New Business

- A. Motion to approve HARB applications-3:0 Recommend motion approval

*Issue: Consider a Motion to approve the May HARB Certificate of Appropriateness*

1. 2025-10-17 N. High St-Sign
2. 2025-16 202 W. Gay St-Convert door to retail window
3. 2025-17-235 E. Market St-Sign

- B. Discuss future revisions to café permits, dining platforms in parking areas, and use of the street during Gay St closure

*Issue: Improvements to regulations for outdoor seating standards and possible ordinance updates.*

Ms. Scimone will email Director Reiner her comments. Mr. Flynn informs Director Reiner that the restaurants on Gay St, during the closure are stacking their equipment in place, rather than the required putting their tables and chairs away. This is creating a safety hazard as fire trucks could not drive down Gay Street in the event of an emergency. Director Reiner did add she has spoken to the Fire Department regarding this.

- C. Subdivision and Land Developments, Conditional Use

1. Motion to approve resolution final subdivision plans for minor lot line change 401 W Washington St., Elks Club – Director Reiner informed the Committee, Planning Commission has provided a letter of support for this project. 3:0 Recommend motion approval
2. West Chester University – Campus Master Plan – conditional use hearing pending. Mr. Metrick reviews the timeline for Master Plan review process; the Planning Commission has started their review in May. They requested some additional Consultant review assistance. Remington & Vernick has been asked to perform a review of the transportation circulation and parking aspects of the plan. Adding beds, reducing parking and street closures to see if the Master Plan was calculated correctly and works. Mr. Metrick offers that he has started a combined review with West Goshen Township to have a more comprehensive review prospective. He would like to schedule time with Borough Council to review this plan later this summer. There is an extension to review until the end of August, he is confident another extension will be requested. Ms. Scimone notes that Council is open for any and all public feedback. Mr. Flynn asks if any high-rise buildings will be built as part of this plan. Mr. Metrick said he was not aware of any new additional buildings on the “super block”, only conversion to residential of an existing building. The bulk of the large construction will be in East Bradford and West Goshen Townships. Ms. Scimone adds that we should keep eyes on losing beds, when the University should be adding beds.
3. Motion to approve resolution final subdivision plan for land development 210-214 W. Washington St -Director Reiner informed the Committee that the Planning Commission did approve with conditions, the Solicitor will need to be consulted about an issue with the Zoning Review. She recommends waiting until July, for clarity and clean reviews by the consultants we do have until July 18 to approve this application. Scott Zwielski, Engineer for applicant, discusses the Zoning letter review and the waivers that will be required and request by the Planning Commission to proceed. No motion was made. Lisa Kerns, W. Biddle St, states she is concerned with the dangerous 7’ site clearance in the alley.

VII. Other business-Director Reiner would like to place the following items on the Work Session agenda for approval, 410 S. Penn St, Zoning Hearing Board Special Exception application from the West Chester School District. At 402 N. Penn St, there is an existing building being used for transitional students, they are asking to the do the same use at 410 S. Penn St. Secondly, Director Reiner recommends all Subdivision and Land Development applications, moving forward would be managed by Pennoni, Township Engineer and also use them as alternative Zoning Officer. There are no major costs associated with this as the cost is covered by Subdivision and Land Development fees. Committee moved these items to the Work Session agenda.

VIII. Adjournment-8:16pm

visit [www.west-chester.com](http://www.west-chester.com) for access to all attachments. Agendas are posted to [www.west-chester.com](http://www.west-chester.com) by noon 3 business days prior to the meeting.

DRAFT

DATE APPLICATION RECEIVED: 06/13/2025

APPLICATION NUMBER: 2025-18 REVISED

PROPERTY ADDRESS: 120 N CHURCH ST WEST CHESTER PA 19380

APPLICANT'S EMAIL: ALLISON@TURKSHEADWINES.COM

Note: All projects must have the appropriate sections completed in its entirety and attached to this form. Only attach the applicable sections. The application number will be assigned by the Building & Housing Department.

1) This application is for (check all appropriate boxes):

- Section #1 - Sign
- Section #2 - Canopy or Awning
- Section #3 - Repair, replacement or alteration from original  
(please supply photos or elevations of original)
- Section #4 - Addition  
(supply architectural elevations and site drawings, as well as photos of the existing structure)
- Section #5 - New Construction  
(supply architectural elevations and site drawings, as well as photos of buildings next to and around the site)
- Section #6 - Demolition

2) Please indicate which items you are submitting with your application form. Do not submit originals, since they will be kept by the HARB for its official archives:

- Color or B/W Sketches
- Old or Historic Photographs
- Plot or Site Plans
- Architectural Elevations
- Photographs of the current existing site showing where changes are to be made, location of buildings and streetscape.

All sketches, elevations, and plans must be signed by the preparer(s)

The owner of this property and the applicant agree to conform to all applicable findings of the Borough of West Chester Historical and Architectural Review Board.

Applicant's name (print): ALLISON OWEN

Applicant's Signature:

Allison Owen

Date:

REVISED 6/12/25  
5/19/25

Owner's Name (print): Adam Low

Owner's Signature:

Date:

DocuSigned by:  
Adam Low  
241B9D9CAB4B4C9

5/19/2025

Note: Check with the Building and Housing office of the Borough of West Chester to see if you need a building permit as well as a Certificate of Appropriateness before you begin your project

DATE APPLICATION RECEIVED: 06/13/2025

APPLICATION NUMBER: 2025-18 REVISED

**SECTION #3 - REPAIR, REPLACEMENT OR ALTERATION**

(Attach a separate Section #3 for each of the repairs, replacements or alterations you wish to make)

**Instructions:** Provide clear photographs showing the location of each proposed improvement, including photos of streetscape and the adjacent buildings. Provide architectural elevations and/or photographs clearly showing the location of the proposed work. Provide material specifications and manufacturer's pamphlets on the replacement materials proposed.

Name of business: TURKS HEAD WINES

Applicant's name: ALISON OWEN

Applicant's address: 120 N CHURCH ST WEST CHESTER PA 19380

Applicant's phone number: 610 719 7307

Owner's name: CHURCH ST MARKET PARTNERS / ADAM LUEN

Owner's address: 120 PENNSYLVANIA AVE MALVERN PA 19355

Owner's telephone number: 610-873-5585

1) Which element do you wish to change:  Doors  Windows  Roofing  Gutters  
 Walls  Steps  Sidewalk  Fence  Trim  Railing  Porch or Balcony  
 Other (specify) ADDING EXTERIOR VENT FOR HOOD SYSTEM IN KITCHEN

2) On how many facades?  Front 1  Side  Back

3) What was the old is the material? BRICK

4) What is the proposed new material? STAINLESS STEEL VENTING PIPE WITH

5) How will it be installed? SIDE OF BUILDING TO ROOF LINE

6) Are you using any historical materials? NO

7) Is so, what and how? -

8) What were the old dimensions? Height: - x Width: - Depth: -

9) What are the new dimensions? Height: - x Width: - Depth: -

10) What were the old colors? N/A

11) What are the new colors? N/A

12) Why do you wish to make these changes? NEED HOOD SYSTEM INSTALLED IN KITCHEN TO COMPLY WITH CODE

REVISION:  
PAINTED  
BLACK  
AND  
REDESIGNED  
PER  
HARB  
REQUEST

**APPLICATION FOR CERTIFICATE OF APPROPRIATENESS**

*Borough of West Chester*  
Historical and Architectural Review Board

**PROJECT ADDRESS:** 120 N. Church Street

- 1) **Date of HARB Review:** June 26, 2025
- 2) **Applicant's Proposal:** Exterior Mechanical Equipment – Revised
- 3) **Findings:**

*The applicant Allison Owen and her mechanical designer/contractor Matt Williamson of Sebastian & Sons were in attendance. Ms. Owen stated she is installing a new commercial kitchen at her Turks Head Wines tasting room and the kitchen requires a commercial exhaust system. The exhaust system is proposed to be located on the building exterior at the rear NW corner of the north facing wall. Ms. Owens previously appeared at the May 29 HARB meeting for a preliminary review and submitted revised the final design documents based on comments provided at that meeting. The final exhaust duct design was described as follows:*

- *The 16-inch diameter ductwork has been relocated as requested to the recessed brick wall panel adjacent to the window (not on the corner pilaster).*
- *The ductwork has been simplified and rotated 90 degrees to reduce its visibility. The duct exits west to the rear alley.*
- *The exterior fan is mounted using standard brackets provided by the manufacturer.*
- *The fan and ductwork will be painted black.*

*The HARB reviewed the application in detail and made the following comments:*

- *The HARB complimented the applicant for the revisions addressing their previous comments.*
- *Discussion focused on whether to discharge the exhaust to the north or west. Points made for both options, eventually consensus was for the north discharge option (rotate 90-degrees).*
- *The ductwork mounting brackets were judged to be overly large and too exposed. Options for providing smaller, better concealed anchorage were discussed. Requested the designers to use equipment anchorage methods that would be less exposed and visually intrusive.*
- *Anchors into the brick wall must be installed in the mortar joints, not the face brick.*
- *The HARB was disappointed that a less visible, in-line vertical exhaust fan was not considered. The applicant said it was too expensive, 10%-15% more.*

- 4) **Recommendations from HARB:**

*The Board recommends Approval of a Certificate of Appropriateness for Application 2025-18 as submitted, with the following modifications and clarifications:*

1. *The final exhaust duct shall be rotated 90-degrees to discharge to the site's north side.*
2. *The system shall be installed using custom equipment mounting brackets that are concealed behind the fan and ductwork components to minimize the mounting system's visibility.*
3. *Anchorage of the mounting brackets to the brick wall will be installed in the mortar joints, not the face brick.*
4. *Exhaust system components will be painted black.*

Application Numbers: [2025-18](#)

**APPLICATION FOR CERTIFICATE OF APPROPRIATENESS**  
*Borough of West Chester*  
Historical and Architectural Review Board

PROJECT ADDRESS: 120 N. Church Street

**5) Borough Council's Action and Date**

- Approved per HARB recommendation:
- Denied for the following reasons:
- Approved with the following differences from HARB recommendation:

.....

Date of Action Taken: \_\_\_\_\_, 2025

Borough Manager's Signature:

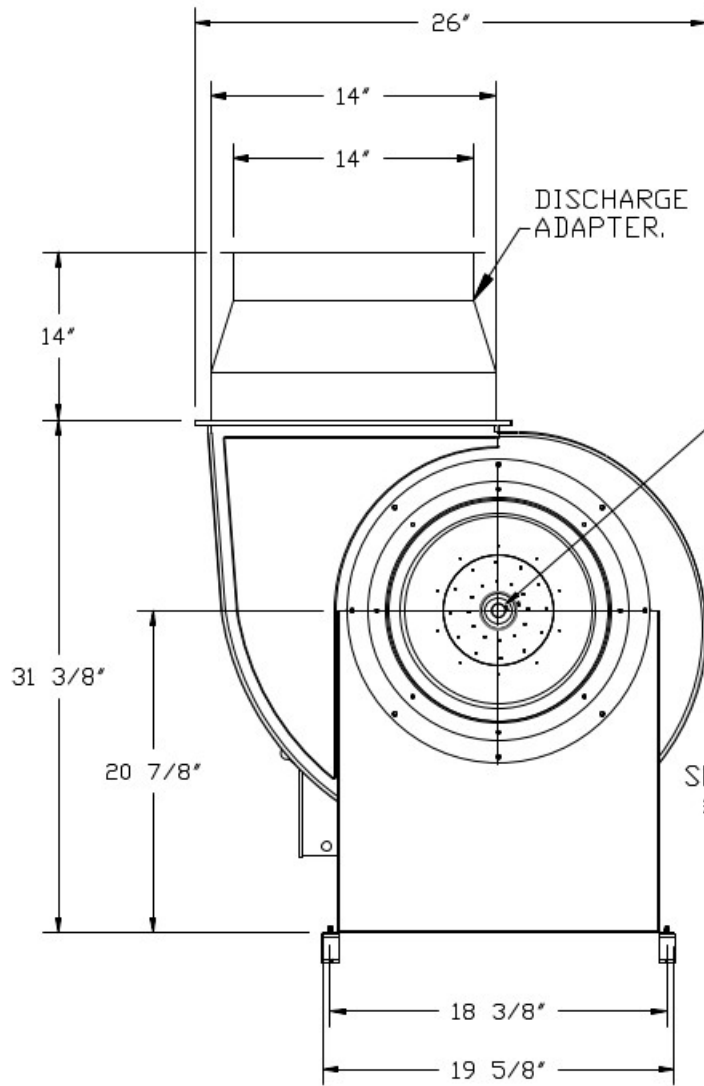

- 7/8" SHAFT DIA.

\*OUTLET NOTES.

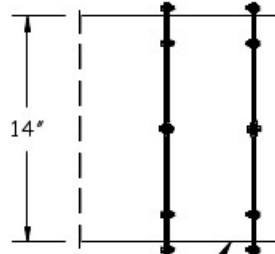

√ICE DUCT-  
LET NOTES.

2" DRAIN.

SERVI  
\*INLE

4.125"

4.1

TORS = USB111, 13 & 15.

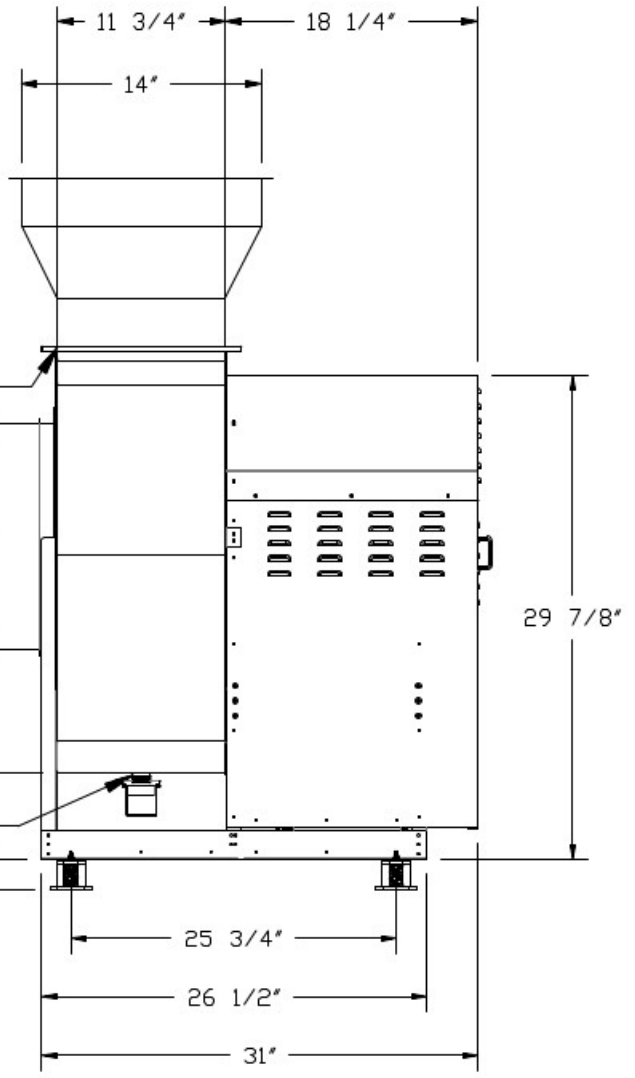

FRONT VIEW



Home Contacts Contractors Submittals Details Workflow Fees Conditions Inspections Other Requirements Notes

Application not yet complete

Project Description: 25118D-CR St Agnes CHOIR Mezzanine  
Add A/C to the choir mezzanine. Install outside Mitsubishi A/C unit and indoor air handler

Permit Number:	COA-25-0011	Applicant:	BRANDYWINE VALLEY HEATING & AIR CONDITIONING, INC
Initial Application Number:	REFERENCE-25-0577	Primary Contact:	BRANDYWINE VALLEY HEATING & AIR CONDITIONING, INC
Permit Type:	CERTIFICATE OF APPROPRIATENESS- REPAIR	Primary Contractor:	BRANDYWINE VALLEY HEATING & AIR CONDITIONING, INC
Status:	INCOMPLETE SUBMITTAL	Last Activity:	06/17/2025 09:55
Process State:	Pending	Last Inspection Date:	
Parent Permit:		Initiated:	06/13/2025
Assigned To:	User WENDY MECKE	Submitted:	06/13/2025 Application is 5 days old
Fast Track:	<input type="checkbox"/>	Completed:	1 of 3 submittals received, 0 of 3 submittals accepted.
Applied for Online:	<input checked="" type="checkbox"/>	Approved:	0 of 3 (0%) steps approved.
		Ready:	\$0.00 paid (100%), \$0.00 due.
		Issued:	
		Finalized:	No inspections.
		Closed:	\$0.00 deferred fees due.
		Expires:	12/10/2025 Exp Override: <input type="checkbox"/>

Site Address

Site Address: 233 W GAY ST [Verify Address and Coordinates](#)

Site City: WEST CHESTER Latitude:

State: PA Site Zip: 19380 Longitude:

Inspection Area:

Zone: TC Town Center

Primary Parcel: 1-8-244

Contact

Contractor: Yes Active:

Display Name: BRANDYWINE VALLEY HEATING & AIR CONDITIONING, INC





























Primary Phone: (610) 692-3900 Primary Email: CFULLER@BVHVAC.COM

Primary Contractor License Number: 4628 Expiration Date: 12/31/2099

Portal Access Code: VTCJV-5NCX8

Mailing Address: 302 COMMERCE DR  
SUITE 100  
EXTON, PA 19341

Permit #: COA-25-0011      Status: INCOMPLETE SUBMITTAL      Contact: BRANDYWINE VALLEY HEATING & AIR CONDITIONING, INC      Site Address: 233 W GAY ST  
Type: CERTIFICATE OF APPROPRIATENESS- REPAIR      Project Name: 25118D-CR St Agnes CHOIR Mezzanine      Contractor: BRANDYWINE VALLEY HEATING & AIR CONDITIONING, INC      WEST CHESTER, PA 19380

Name	Value
REASON FOR APPROPRIATENESS APPLICATION:*	Replacement or alteration from original  
LOCATION OF PROJECT:*	233 W Gay Street  
NAME OF BUSINESS:*	St Agnes Church  
WHICH ELEMENTS DID YOU CHANGE:	Adding A/C unit on the side.  
ON HOW MANY FACADES:	<input type="text"/>  
WHAT WAS THE OLD IS THE MATERIAL:	<input type="text"/>  
WHAT IS THE PROPOSED NEW MATERIAL:	<input type="text"/>  
HOW WILL IT BE INSTALLED:	<input type="text"/>  
ARE YOU USING ANY HISTORICAL MATERIALS:	<input type="text"/>  
IF SO, WHAT AND HOW:	<input type="text"/>  
WHAT WERE THE OLD DIMENSIONS:	<input type="text"/> 
WHAT ARE THE NEW DIMENSIONS:	<input type="text"/>  
WHAT ARE THE OLD COLORS:	<input type="text"/>  
WHAT ARE THE NEW COLORS:	<input type="text"/>  
WHY DO YOU WISH TO MAKE THESE CHANGES:	<input type="text"/>  

**APPLICATION FOR CERTIFICATE OF APPROPRIATENESS**

*Borough of West Chester*  
Historical and Architectural Review Board

**PROJECT ADDRESS:** 233 W. Gay Street

- 1) **Date of HARB Review:** June 26, 2025
- 2) **Applicant's Proposal:** Exterior HVAC Equipment – Choir Mezzanine
- 3) **Findings:**

*The project is for the installation of a new exterior HVAC condensing unit at the St. Agnes Church, to serve the choir mezzanine. Carol Quigley appeared on behalf of the applicant, Brandywine Heating and Air Conditioning, to present the project. Ms. Quigley described the final project as follows:*

- *Install one new exterior condensing unit on the west side of the St. Agnes Church Building, in front of two existing basement level windows.*
- *The condensing unit will be mounted at grade on a concrete pad.*
- *New shrubbery will be installed to fully conceal the condensing unit from public view.*

*The HARB reviewed the application in detail. There was some confusion regarding the mechanical piping and electrical wiring connections from the church to the condensing unit. No mention is made about this in the application. The existing church has stone exterior walls. Visible penetrations and/or surface routing of the piping is not appropriate on this distinctive building. Ms. Quigley reported she was told the connections would not be visible, but no details were provided to her. The HARB conjectured the connections could be routed below grade.*

*To keep the project on track, the HARB made a motion based on “concealed” connections. Should the actual design be different, the applicant will need to submit updated design details for further review.*

- 4) **Recommendations from HARB:**

*The Board recommends Approval of a Certificate of Appropriateness for Application 2025-20 as submitted, with the following clarification:*

1. *The approval is based on the requirement that there will be no visible above-grade piping or wiring connections to the condensing unit from the church building.*

Application Numbers: [2025-20](#)

**APPLICATION FOR CERTIFICATE OF APPROPRIATENESS**

*Borough of West Chester*  
Historical and Architectural Review Board

PROJECT ADDRESS: [233 W. Gay Street](#)

**5) Borough Council's Action and Date**

- Approved per HARB recommendation:
- Denied for the following reasons:
- Approved with the following differences from HARB recommendation:

.....

Date of Action Taken: \_\_\_\_\_, 2025

Borough Manager's Signature:

## St Agnes 233 W Gay Street AC Replacement for Choir Mezzanine

Straight on view of outside equipment location.

Mitsubishi A/C unit to be place between the shrubbs and window. The unit will be placed on a 3 ft x 1.5 ft concrete slab.

The existing shrubbery will remain and trimmed appropriately. St. Agnes' maintenance personnel will plant additional evergreen shrubbery to screen from public view, if necessary.



Straight on view from Gay Street.



Angled view from Gay Street.

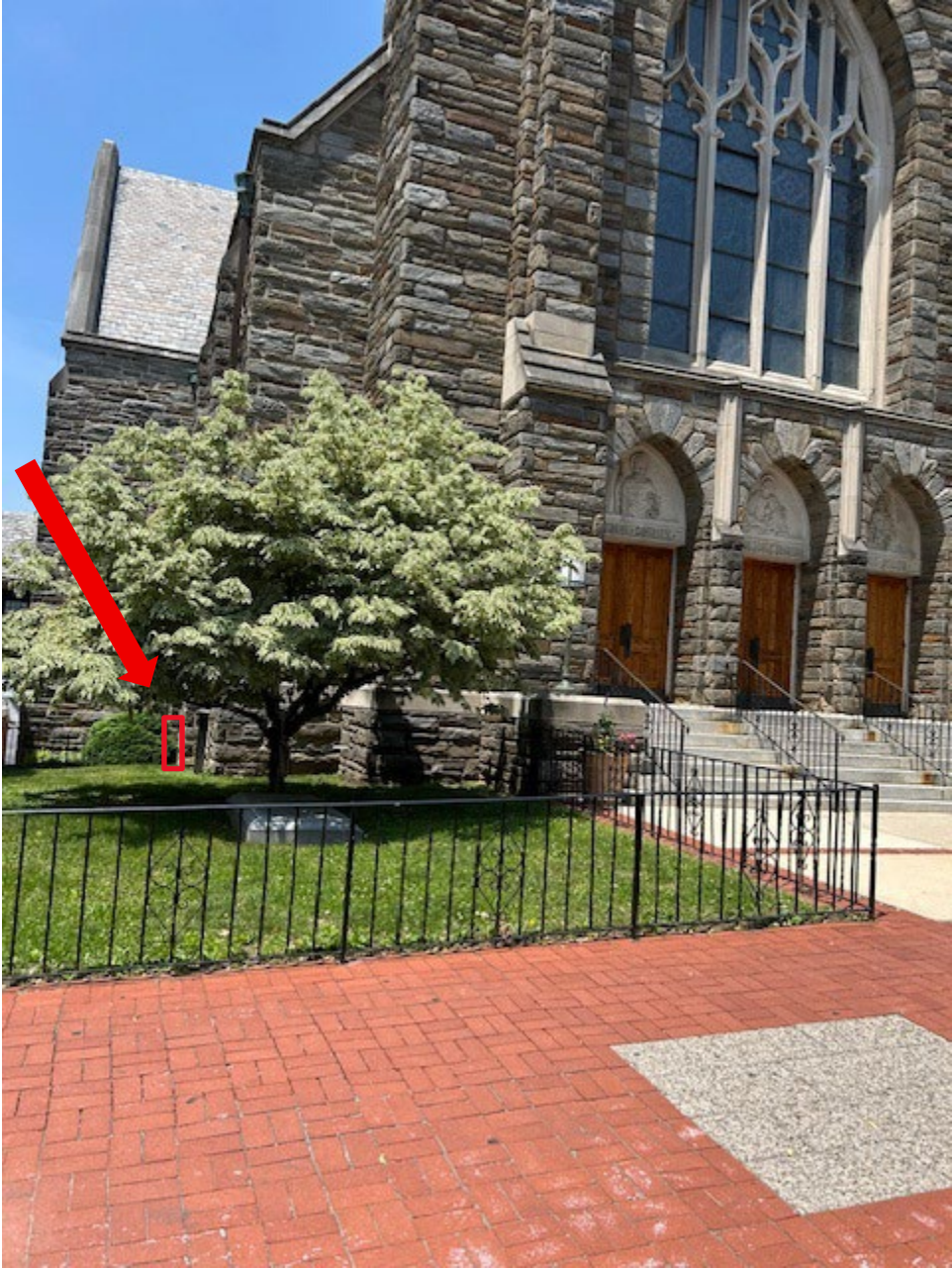



St. Agnes Mitsubishi install for Choir Mezzanine

Location of outside equipment is circled.

**MSY-GS30NA2 & MUY-GS30NA2**  
**30,000 BTU/H WALL-MOUNTED INDOOR UNIT**  
**30,000 BTU/H COOLING ONLY OUTDOOR UNIT**



Job Name:

System Reference:

Date:



Indoor Unit.....MSY-GS30NA2

Outdoor Unit.....MUY-GS30NA2



←-----Outdoor equipment

**INDOOR UNIT FEATURES**

- Dual Barrier Coating
- Slim wall-mounted indoor units provide zone comfort control
- The outdoor unit powers the indoor unit, and should a power outage occur, the system is automatically restarted when power returns
- Multiple fan speed options: Low, Medium, High, Super-high
  - Auto and Powerful modes available in addition to the four fan speeds
- Multiple control options available:
  - Back-lit screen handheld remote controller (provided with the unit)
  - kumo cloud® smart device app for remote access
  - Third-party interface options
  - Wired or wireless controllers
- Hot-Start Technology: no cold air rush at equipment startup or when restarting after defrost cycle
- Powerful Operation: quickly cools or heats the room by automatically adjusting fan speed and set temperature for 15 minutes
- Weekly Timer: easily set desired temperatures and operation ON/OFF times to match your lifestyle
- Smart Set: recalls a preferred preset temperature setting at the touch of a button
- Smart Dry Mode: improved moisture removal is achieved by optimizing the control of the indoor fan, compressor, and heat exchanger
- Wide Vane mode provides an airflow of 150° in heating and 100° in cooling
- Nano Platinum Filter: incorporates nanometer-sized platinum-ceramic particles that kill bacteria and deodorize air
- Anti-allergy Enzyme Filter: traps allergens such as molds and bacteria and decomposes them using enzymes

**OUTDOOR UNIT FEATURES**

- INVERTER-driven compressor and LEV provide high efficiency and comfort while using only the energy needed to maintain maximum performance
- Blue Fin anti-corrosion treatment applied to the outdoor unit heat exchanger for increased coil protection and longer life
  - Rated for 2,000 hours spraying time per ASTM B117 Standard

# SPECIFICATIONS: MSY-GS30NA2 & MUY-GS30NA2

Cooling at 95°F <sup>1</sup>	Maximum Capacity	BTU/H	30,600
	Rated Capacity	BTU/H	30,600
	Minimum Capacity	BTU/H	10,300
	Maximum Power Input	W	3,320
	Rated Power Input	W	3,320
	Moisture Removal	Pints/h	7.8
	Sensible Heat Factor		0.72
	Power Factor [208V / 230V]	%	98.0 / 98.0
Efficiency	SEER2		19.2
	EER2 <sup>1</sup>		9.2
	HSPF2 [IV]		—
	ENERGY STAR® Certified		No
Electrical	Voltage, Phase, Frequency		208/230, 1, 60
	Guaranteed Voltage Range	V AC	187 - 253
	Voltage: Indoor - Outdoor, S1-S2	V AC	208/230
	Voltage: Indoor - Outdoor, S2-S3	V DC	24
	Short-circuit Current Rating [SCCR]	kA	5
	Recommended Fuse/Breaker Size (Outdoor)	A	25
	Recommended Wire Size [Indoor - Outdoor]	AWG	14
	Power Supply		Indoor unit is powered by the outdoor unit
Indoor Unit	MCA	A	1.0
	Fan Motor Full Load Amperage	A	0.76
	Fan Motor Output	W	56
	Airflow Rate at Cooling, Dry	CFM	379–613–710–932
	Airflow Rate at Cooling, Wet	CFM	341–552–639–839
	Sound Pressure Level [Cooling]	dB[A]	34–42–49–53
	Drain Pipe Size	In. [mm]	5/8 [16]
	Coating on Heat Exchanger		—
	External Finish Color		White(Munsell 1.0Y 9.2/0.2)
	Unit Dimensions	W x D x H: In. [mm]	46-1/16 x 11-5/8 x 14-3/8 [1,170 x 295 x 365]
	Package Dimensions	W x D x H: In. [mm]	51 x 18-1/2 x 14-1/4 [1,300 x 470 x 360]
	Unit Weight	Lbs. [kg]	45 [20]
Package Weight	Lbs. [kg]	52 [23]	
Indoor Unit Operating Temperature Range	Cooling Intake Air Temp [Maximum / Minimum]*	°F	90 DB, 73 WB / 67 DB, 57 WB
Outdoor Unit	MCA	A	22.0
	MOCP	A	25
	Fan Motor Full Load Amperage	A	0.93
	Fan Motor Output	W	50
	Airflow Rate [Cooling / Heating]	CFM	56
	Refrigerant Control		LEV
	Defrost Method		N/A
	Sound Pressure Level, Cooling <sup>1</sup>	dB(A)	55
	Compressor Type		Twin Rotary
	Compressor Model		SNB220FQAM1T
	Compressor Rated Load Amps	A	13.8
	Compressor Locked Rotor Amps	A	17.3
	External Finish Color		Munsell 3Y 7.8/1.1
	Unit Dimensions	W x D x H: In. [mm]	33-1/16 x 13 x 34-5/8 [840 x 330 x 880]
	Package Dimensions	W x D x H: In. [mm]	38-3/4 x 16-3/4 x 39 [980 x 420 x 990]
Unit Weight	Lbs. [kg]	122 [55]	
Package Weight	Lbs. [kg]	138 [63]	
Outdoor Unit Operating Temperature Range	Cooling Air Temp [Maximum / Minimum]*	°F	115 DB / 14 DB
	Cooling Thermal Lock-out / Re-start Temperatures**	°F	-4 / 0
Refrigerant	Type		R410A
	Pre-Charged Refrigerant Amount	Lbs, oz	4.0, 5.0
	Maximum Pre-Charged Piping Length	Ft. [m]	25.0 [7.5]
	Additional Refrigerant Charge Per Additional Piping Length	oz./Ft. [g/m]	1.08 [20]
Piping	Gas Pipe Size O.D. [Flared]	In.[mm]	5/8 [15.88]
	Liquid Pipe Size O.D. [Flared]	In.[mm]	1/4 [6.35]
	Maximum Piping Length	Ft. [m]	100 [30]
	Maximum Height Difference	Ft. [m]	50 [15]
	Maximum Number of Bends		10

**NOTES:**

AHRI Rated Conditions

(Rated data is determined at a fixed compressor speed)

<sup>1</sup>Cooling (Indoor // Outdoor)

<sup>2</sup>Heating at 47°F (Indoor // Outdoor)

<sup>3</sup>Heating at 17°F (Indoor // Outdoor)

°F 80 DB, 67 WB // 95 DB, 75 WB

°F 70 DB, 60 WB // 47 DB, 43 WB

°F 70 DB, 60 WB // 17 DB, 15 WB

\*Indoor/Outdoor Unit Operating Temperature Range (Cooling Air Temp [Maximum / Minimum]):

• Applications should be restricted to comfort cooling only; equipment cooling applications are not recommended for low ambient temperature conditions.

\*\*Outdoor Unit Operating Temperature Range (Cooling Thermal Lock-out / Re-start Temperatures):

• System cuts out in heating mode to avoid thermistor error and automatically restarts at these temperatures.

## INDOOR UNIT ACCESSORIES: MSY-GS30NA2

Control Interface	IT Extender	PAC-WHS01IE-E
	kumo station® for kumo cloud®	PAC-WHS01HC-E
	Procon BACnet® and Modbus® Interface	PAC-UKPRC001-CN-1
	System Control Interface	MAC-334IF-E
	Thermostat Interface	PAC-US445CN-1
	USNAP Adapter	PAC-WHS01UP-E
	Wireless Interface for kumo cloud®	PAC-USWHS002-WF-2
Remote Sensor	Wired Remote Sensor	M21EAA307
	Wireless temperature and humidity sensor for kumo cloud®	PAC-USWHS003-TH-1
Wired Remote Controller	Deluxe Wired MA Remote Controller†	PAR-40MAAU
	Simple Ductless Wired Remote Controller	PAC-SDW01RC-1
	Simple MA Remote Controller†	PAC-YT53CRAU-J
	Touch MA Controller†	PAR-CT01MAU-SB
Wireless Remote Controller	kumo touch™ RedLINK™ Wireless Controller	MHK2
	Lockdown bracket for remote controller	RCMKP1CB
Condensate	Blue Diamond (Advanced) Mini Condensate Pump w/ Reservoir & Sensor (208/230V) [recommended]	X87-721
	Blue Diamond (MegaBlue Advanced) Condensate Pump w/ Reservoir & Sensor	X87-835
	Blue Diamond Alarm Extension Cable — 6.5 Ft.	C13-192
	Blue Diamond MultiTank — collection tank for use with multiple pumps	C21-014
	Blue Diamond Sensor Extension Cable — 15 Ft.	C13-103
	Drain Pan Level Sensor/Control	SS610E
	Refco Condensate Pump (100-240 VAC)	GOBI-II
	Refco Condensate Pump (100-240 VAC) up to 120,000 BTU/H	COMBI
	Sauerermann Condensate Pump	SI30-230
Disconnect Switch	(30A/600V/UL) [fits 2" X 4" utility box] - Black	TAZ-MS303
	(30A/600V/UL) [fits 2" X 4" utility box] - White	TAZ-MS303W
Lineset	100' x 1/4" x 100' x 5/8" Lineset (Twin-Tube Insulation)	MLS145812T-100
	15' x 1/4" x 15' x 5/8" Lineset (Twin-Tube Insulation)	MLS145812T-15
	30' x 1/4" x 30' x 5/8" Lineset (Twin-Tube Insulation)	MLS145812T-30
	50' x 1/4" x 50' x 5/8" Lineset (Twin-Tube Insulation)	MLS145812T-50
	65' x 1/4" x 65' x 5/8" Lineset (Twin-Tube Insulation)	MLS145812T-65

**NOTES:**

†Requires MAC-334IF-E

- M-Series EZ FIT® Recessed Ceiling Cassette, Floor-mount and Wall-mount  
Allows indoor units to connect to an MA Controller:
  - Deluxe MA Remote Controller
  - Simple MA Controller
  - Touch MA Controller

## OUTDOOR UNIT ACCESSORIES: MUY-GS30NA2

Air Outlet Guide	Air Outlet Guide	MAC-890SG-E
Control/Service Tool	M- & P-Series Maintenance Tool Cable Set	M21EC0397
	Maintenance Tool Interface	PAC-USCMS-MN-1
Drain Socket	Drain Socket	MAC-871DS
Hail Guards	Hail Guard	HG-A7
Mini-Split Wire	14 Gauge, 4 wire MiniSplit Cable—250 ft. roll	SW144-250
	14 Gauge, 4 wire MiniSplit Cable—50 ft. roll	SW144-50
	16 Gauge, 4 wire MiniSplit Cable—250 ft. roll	SW164-250
	16 Gauge, 4 wire MiniSplit Cable—50 ft. roll	SW164-50
Mounting Pad	Condensing Unit Mounting Pad: 16" x 36" x 3"	ULTRILITE1
	Outdoor Unit 3-1/4 inch Mounting Base (Pair) - Plastic	DSD-400P
Stand	18" Single Fan Stand	QSMS1801M
	24" Single Fan Stand	QSMS2401M
	Condenser Wall Bracket	QSWB2000M-1
	Condenser Wall Bracket - Stainless Steel Finish	QSWBSS
	Outdoor Unit Stand — 12" High	QSMS1201M

# INDOOR UNIT DIMENSIONS: MSY-GS30NA2

Unit : inch

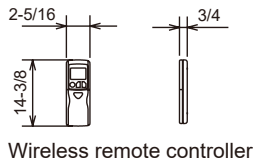
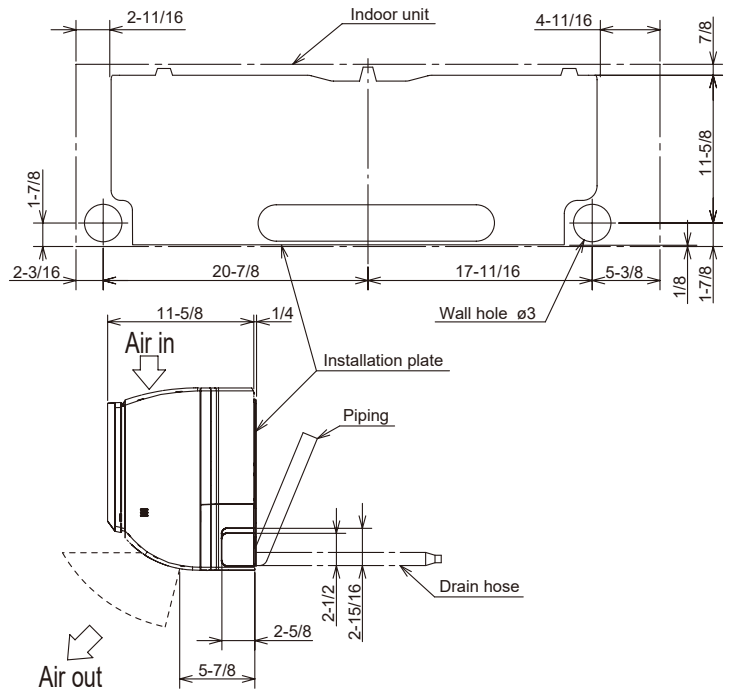
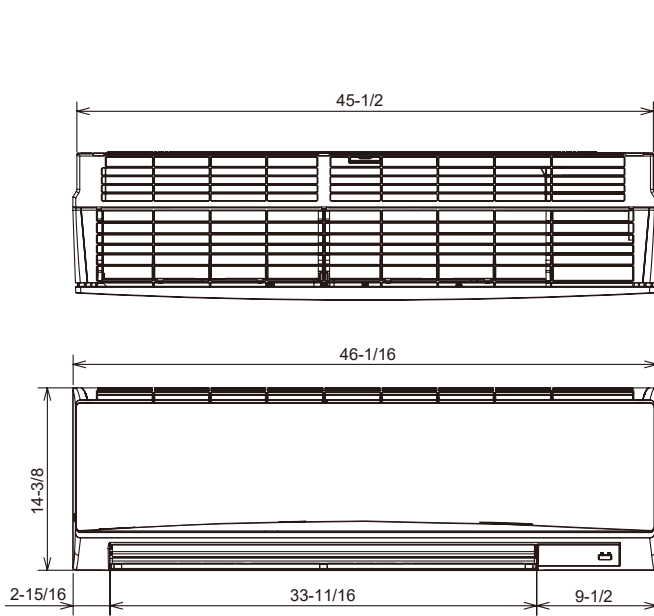

	PIPING	INSULATION
LIQUID LINE	$\phi 3/8 - 19-11/16$ (FLARED CONNECTION $\phi 1/4$ )	$\phi 1-1/4$ O.D $\phi 9/16$ I.D
GAS LINE	$\phi 15/32 - 17-13/16$ (FLARED CONNECTION $\phi 5/8$ )	$\phi 1-7/16$ O.D $\phi 13/16$ I.D
DRAIN HOSE	INSULATION $\phi 1-1/8$ CONNECTED PART $\phi 5/8$ O.D	

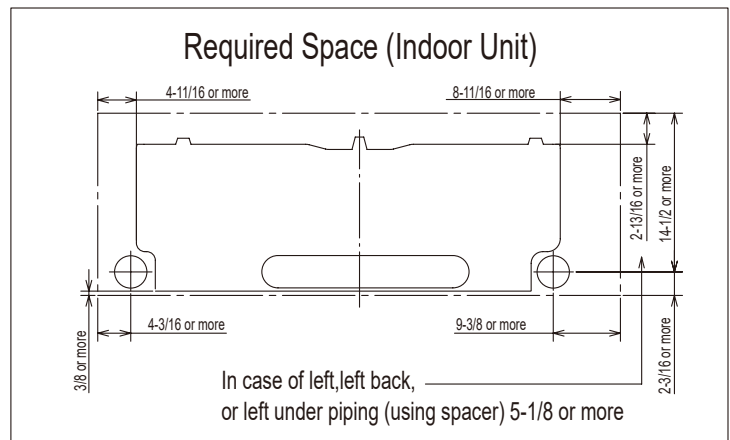

# OUTDOOR UNIT DIMENSIONS: MUY-GS30NA2

Unit: inch

## REQUIRED SPACE

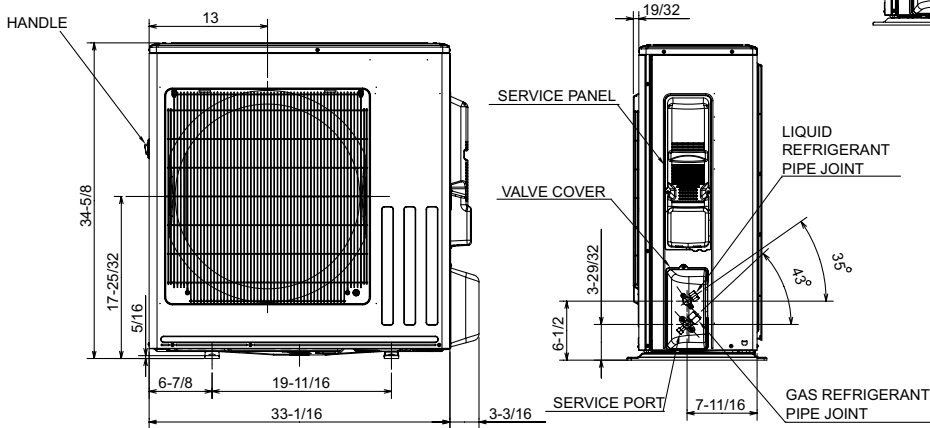
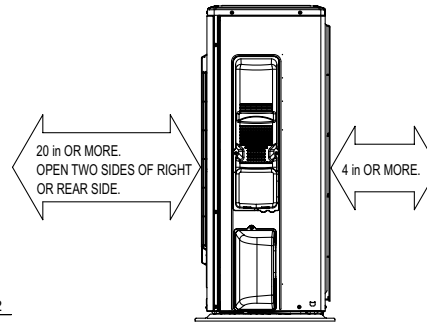
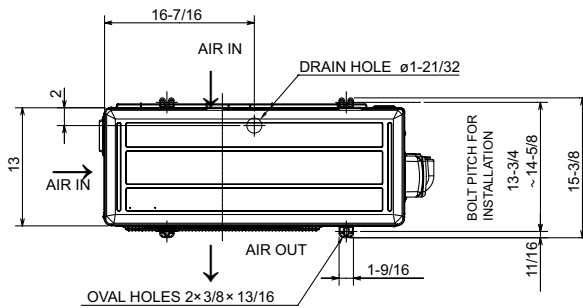
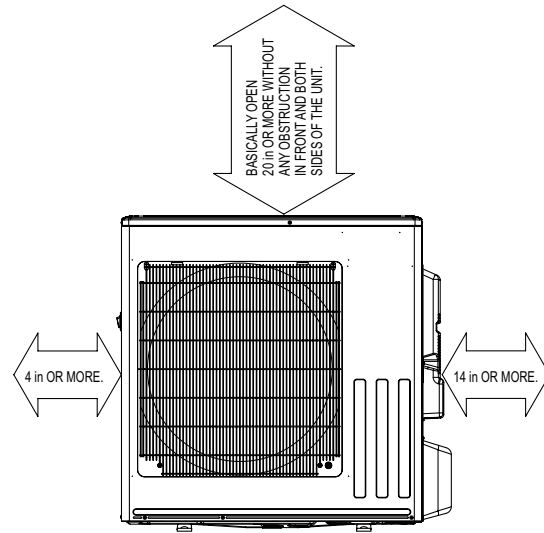

REFRIGERANT PIPE JOINT	LIQUID REFRIGERANT PPE	FLARED $\phi 6.35$ (1/4")
	GAS REFRIGERANT PPE	FLARED $\phi 15.88$ (5/8")

1340 Satellite Boulevard Suwanee, GA 30024  
Toll Free: 800-433-4822 www.mehvac.com

FORM# MSY-GS30NA2 & MUY-GS30NA2 - 202312



Current processing time is 20 days (In review 20 days)

Project Description: 25117D-CR St Agnes Rectory office AC replacement & Add A/C to the choir mezzanine. Install outside Mitsubishi A/C unit and indoor air handler

Permit Number:	COA-25-0010	Applicant:	BRANDYWINE VALLEY HEATING & AIR CONDITIONING, INC
Initial Application Number:	REFERENCE-25-0527	Primary Contact:	BRANDYWINE VALLEY HEATING & AIR CONDITIONING, INC
Permit Type:	CERTIFICATE OF APPROPRIATENESS- REPAIR	Primary Contractor:	BRANDYWINE VALLEY HEATING & AIR CONDITIONING, INC
Status:	INCOMPLETE SUBMITTAL	Last Activity:	06/17/2025 10:32
Process State:	Pending	Last Inspection Date:	
Parent Permit:		Initiated:	05/29/2025
Assigned To:	User WENDY MECKE	Submitted:	05/29/2025 Application is 20 days old
Fast Track:	<input type="checkbox"/>	Completed:	05/29/2025 2 of 4 submittals received, 1 of 4 submittals accepted.
Applied for Online:	<input checked="" type="checkbox"/>	Approved:	0 of 3 (0%) steps approved.
		Ready:	\$0.00 paid (100%), \$0.00 due.
		Issued:	
		Finalized:	No inspections.
		Closed:	\$0.00 deferred fees due.
		Expires:	11/25/2025 Exp Override: <input type="checkbox"/>

Site Address

Site Address: 233 W GAY ST Verify Address and Coordinates

Site City: WEST CHESTER Latitude:

State: PA Site Zip: 19380 Longitude:

Inspection Area:

Zone: TC Town Center

Contractors Submittals Details Workflow Fees Permits Inspections Other Requirements Notes

**Contact** Phone Numbers Email Addresses Details Secure Details Points of Contact Contractor License Portal Accounts

**Contractor:** Yes **Active:**

**Display Name:** BRANDYWINE VALLEY HEATING & AIR CONDITIONING, INC

**Primary Phone:** (610) 692-3900 **Primary Email:** CFULLER@BVHVAC.COM

**Primary Contractor License Number:** 4628 **Expiration Date:** 12/31/2099





























**Portal Access Code:** VTCJV-5NCX8

**Mailing Address**

302 COMMERCE DR  
SUITE 100  
EXTON, PA 19341

**Physical Address**

Permit #: COA-25-0010      Status: INCOMPLETE SUBMITTAL      Contact: BRANDYWINE VALLEY HEATING & AIR CONDITIONING, INC      Site Address: 233 W GAY ST  
 Type: CERTIFICATE OF APPROPRIATENESS- REPAIR      Project Name: 25117D-CR St Agnes      Contractor: BRANDYWINE VALLEY HEATING & AIR CONDITIONING, INC      WEST CHESTER, PA 19380

Name	Value
REASON FOR APPROPRIATENESS APPLICATION:*	Repair  
LOCATION OF PROJECT:*	233 W Gay Street  
NAME OF BUSINESS:*	St Agnes Church  
WHICH ELEMENTS DID YOU CHANGE:	add HVAC equipment side of the building  
ON HOW MANY FACADES:	<input type="text"/>  
WHAT WAS THE OLD IS THE MATERIAL:	<input type="text"/>  
WHAT IS THE PROPOSED NEW MATERIAL:	<input type="text"/>  
HOW WILL IT BE INSTALLED:	<input type="text"/>  
ARE YOU USING ANY HISTORICAL MATERIALS:	<input type="text"/>  
IF SO, WHAT AND HOW:	<input type="text"/>  
WHAT WERE THE OLD DIMENSIONS:	<input type="text"/> 
WHAT ARE THE NEW DIMENSIONS:	<input type="text"/>  
WHAT ARE THE OLD COLORS:	<input type="text"/>  
WHAT ARE THE NEW COLORS:	<input type="text"/>  
WHY DO YOU WISH TO MAKE THESE CHANGES:	Replacing the AC for the office  

**APPLICATION FOR CERTIFICATE OF APPROPRIATENESS**

*Borough of West Chester*  
Historical and Architectural Review Board

**PROJECT ADDRESS:** 233 W. Gay Street

- 1) **Date of HARB Review:** June 26, 2025
- 2) **Applicant's Proposal:** Exterior HVAC Equipment – Rectory Office
- 3) **Findings:**

*The project is for the installation of a new exterior HVAC condensing unit at the St. Agnes Rectory Building to serve the Rectory office. Carol Quigley appeared on behalf of the applicant, Brandywine Heating and Air Conditioning, to present the project. There was some confusion because the most recent June 25, 2025 design documents were not available for HARB review. Ms. Quigley provided clarification and described the final project as follows:*

- *Install one new exterior condensing unit on a ground mounted concrete pad.*
- *To conceal the electrical and mechanical equipment connections to the building, the piping and wiring will be routed through a new penetration in the exterior brick building wall, down low and directly behind the condensing unit.*
- *New shrubbery will be installed to fully conceal the condensing unit from public view.*
- *Two adjacent existing, large metal wall vents will be removed, and the openings infilled with matching brick and mortar. The new brick will be keyed into the existing brick wall.*

*The HARB reviewed the application in detail. Based on Ms. Quigley's clarification of the most recent design details, the proposed project was found to be well designed and appropriate.*

- 4) **Recommendations from HARB:**

*The Board recommends Approval of a Certificate of Appropriateness for Application 2025-19 as submitted, with the following clarification:*

1. *The approval is based on the most recent design documents submitted on June 25, 2025.*

Application Numbers: [2025-19](#)

**APPLICATION FOR CERTIFICATE OF APPROPRIATENESS**

*Borough of West Chester*  
Historical and Architectural Review Board

PROJECT ADDRESS: [233 W. Gay Street](#)

**5) *Borough Council's Action and Date***

- Approved per HARB recommendation:
- Denied for the following reasons:
- Approved with the following differences from HARB recommendation:

.....

Date of Action Taken: \_\_\_\_\_, 2025

Borough Manager's Signature:



St. Agnes Mitsubishi install for Rectory

The location of outside equipment is circled.

St Agnes 233 W Gay Street AC Replacement for Rectory

View of AC unit location from Gay Street



Straight on view of AC location. The new system will come through the wall at the upper level and run down to outdoor unit. It will look similar to a gutter drainage pipe, but it's a better material. The outdoor unit will be placed on a 3 ft x 1.5 ft concrete slab.

The existing vents (circled in blue below) will be removed, and the surrounding brick wall will be repaired/refaced by St. Agnes' maintenance personnel.

St. Agnes' maintenance personnel will plant additional evergreen shrubbery around the unit to screen from public view.



View of AC unit location from New Street. Vents in the wall will be removed and filled in with brick. Bushes to be planted around unit.



Not preferred, but the alternate location for the AC unit would be up on the back roof. Not visible from Gay Street.



View from New Street of the alternate location.

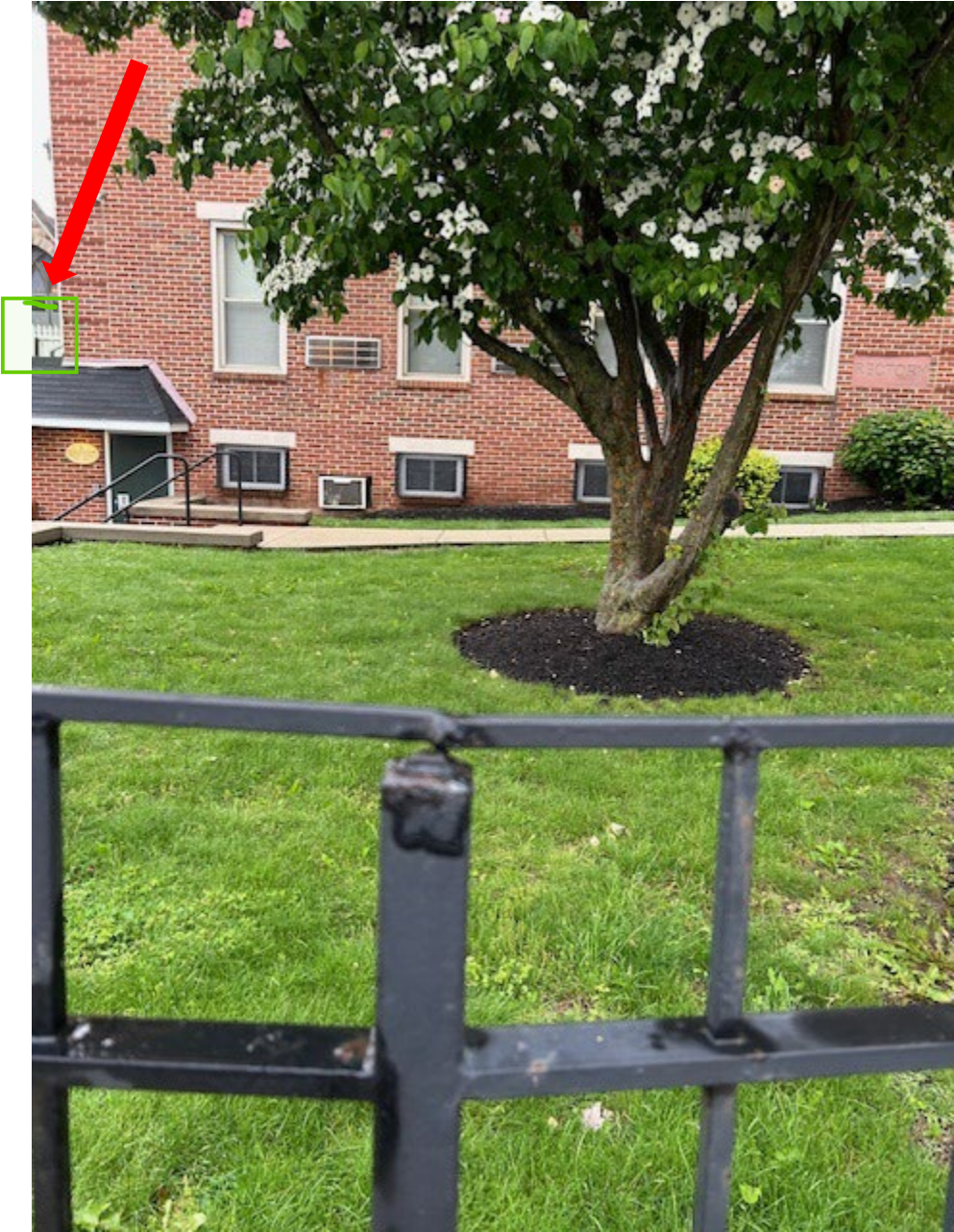

# MSZ-GS12NA

## 12,000 BTU/H WALL-MOUNTED INDOOR UNIT



Job Name:

System Reference:

Date:



### GENERAL FEATURES

- Slim wall-mounted indoor units provide zone comfort control
- Dual Barrier Coating applied to the heat exchanger, vanes and fan to prevent hydrophilic and hydrophobic dirt build-up
- Optional Microparticle Filter designed to capture PM2.5
- The outdoor unit powers the indoor unit, and should a power outage occur, the system is automatically restarted when power returns
- Quiet operation
- Smart Set: recalls a preferred preset temperature setting at the touch of a button
- Built-in backup/auxiliary heater control available
- Multiple fan speed options: Quiet, Low, Medium, High, Super-high, Auto
- Multiple control options available:
  - Back-lit screen handheld remote controller (provided with the unit)
  - kumo cloud® smart device app for remote access
  - Third-party interface options
  - Wired or wireless controllers

Specifications		System
Unit Type		MSZ-GS12NA
Cooling Capacity <sup>1,3</sup>	BTU/H	12,000
Heating Capacity <sup>2,3</sup>	BTU/H	14,400
Electrical	Voltage, Phase, Frequency	208/230, 1, 60
	Guaranteed Voltage Range	187 - 253
	Voltage: Indoor - Outdoor, S1-S2	V AC 208/230
	Voltage: Indoor - Outdoor, S2-S3	V DC 24
	Short-circuit Current Rating [SCCR]	kA 5
Indoor Unit	MCA	A 1.0
	Fan Motor Full Load Amperage	A 0.5
	Fan Motor Output	W 30
	Airflow Rate at Cooling, Dry	CFM 134-160-222-307-381
	Airflow Rate at Cooling, Wet	CFM 121-144-200-276-343
	Airflow Rate at Heating, Dry	CFM 134-160-222-307-390
	Sound Pressure Level [Cooling]	dB[A] 19-22-30-37-45
	Sound Pressure Level [Heating]	dB[A] 19-22-30-37-43
	Drain Pipe Size	In. [mm] 5/8 [15.88]
	Coating on Heat Exchanger	Dual Barrier Coating
	External Finish Color	Munsell 1.0Y 9.2/0.2
	Unit Dimensions	W x D x H: In. [mm] 31-7/16 x 9-1/8 x 11-5/8 [798 x 232 x 295]
	Package Dimensions	W x D x H: In. [mm] 33-1/2 x 12 x 14 [850 x 300 x 350]
	Unit Weight	Lbs. [kg] 23 [10.4]
	Package Weight	Lbs. [kg] 26 [11.5]
Refrigerant	Type R410A	
Piping	Gas Pipe Size O.D. [Flared]	In.[mm] 3/8 [9.52]
	Liquid Pipe Size O.D. [Flared]	In.[mm] 1/4 [6.35]

NOTES:  
 Conditions <sup>1</sup>Cooling (Indoor // Outdoor) °F 80 DB, 67 WB // 95 DB, 75 WB  
<sup>2</sup>Heating at 47°F (Indoor // Outdoor) °F 70 DB, 60 WB // 47 DB, 43 WB

<sup>3</sup>Capacity varies based on the number of indoor units operating and the model of the Multi-zone Outdoor Unit. For reference to connected capacity charts, please refer Multi-zone Outdoor Unit Operational Performance.

## INDOOR UNIT ACCESSORIES: MSZ-GS12NA

Control Interface	BACnet® and Modbus® Interface	PAC-UKPRC001-CN-1
	CN24 Relay Kit	CN24RELAY-KIT-CM3
	IT Extender	PAC-WHS01IE-E
	kumo station® for kumo cloud®	PAC-WHS01HC-E
	System Control Interface	MAC-334IF-E
	Thermostat Interface	PAC-US444CN-1
	Thermostat Interface	PAC-US445CN-1
	USNAP Adapter	PAC-WHS01UP-E
	Wireless Interface for kumo cloud®	PAC-USWHS002-WF-2
Remote Sensor	Wired Remote Sensor	M21EAA307
	Wireless temperature and humidity sensor for kumo cloud®	PAC-USWHS003-TH-1
Wired Remote Controller	Deluxe Wired MA Remote Controller†	PAR-40MAAU
	Simple Ductless Wired Remote Controller	PAC-SDW01RC-1
	Simple MA Remote Controller†	PAC-YT53CRAU-J
	Touch MA Controller†	PAR-CT01MAU-SB
Wireless Remote Controller	kumo touch™ RedLINK™ Wireless Controller	MHK2
	Lockdown bracket for remote controller	RCMKP1CB
Condensate	Blue Diamond (Advanced) Mini Condensate Pump w/ Reservoir & Sensor (208/230V) [recommended]	X87-721
	Blue Diamond (MegaBlue Advanced) Condensate Pump w/ Reservoir & Sensor	X87-835
	Blue Diamond Alarm Extension Cable — 6.5 Ft.	C13-192
	Blue Diamond MultiTank — collection tank for use with multiple pumps	C21-014
	Blue Diamond Sensor Extension Cable — 15 Ft.	C13-103
	Drain Pan Level Sensor/Control	SS610E
	Fascia Kit for MicroBlue Pump, mounts the MicroBlue and sensor directly beneath indoor unit	T18-016
	Refco Condensate Pump (100-240 VAC)	GOBI-II
	Refco Condensate Pump (100-240 VAC) up to 120,000 BTU/H	COMBI
Saueremann Condensate Pump	SI30-230	
Disconnect Switch	(30A/600V/UL) [fits 2" X 4" utility box] - Black	TAZ-MS303
	(30A/600V/UL) [fits 2" X 4" utility box] - White	TAZ-MS303W
Filter	Anti-allergy Enzyme Filter	MAC-408FT-E
	Microparticle (PM2.5) Filter	MAC-EMF515FT-E

**NOTES:**

†Requires MAC-334IF-E

- M-Series EZ FIT® Recessed Ceiling Cassette, Floor-mount and Wall-mount  
Allows indoor units to connect to an MA Controller:
  - Deluxe MA Remote Controller
  - Simple MA Controller
  - Touch MA Controller

# INDOOR UNIT DIMENSIONS: MSZ-GS12NA

Unit: inch

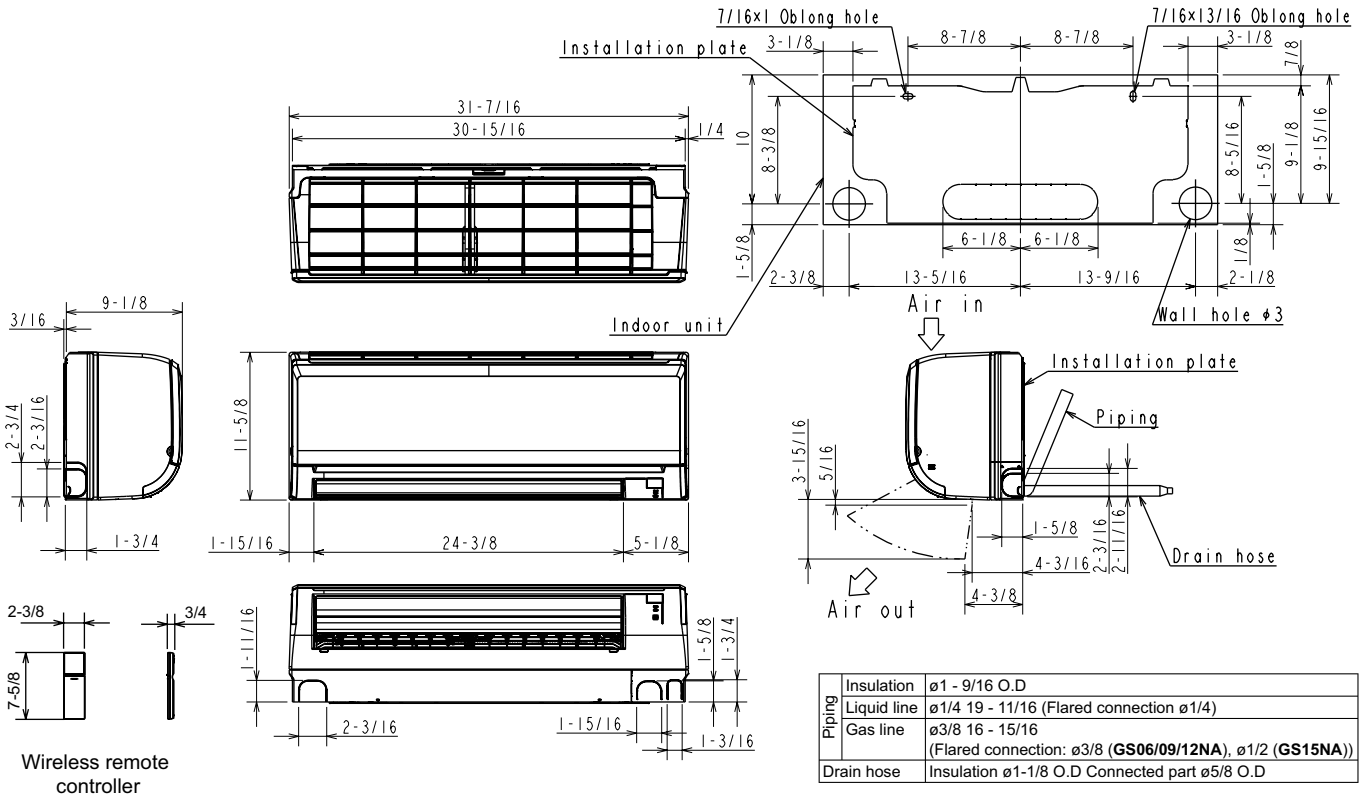

1340 Satellite Boulevard Suwanee, GA 30024  
Toll Free: 800-433-4822 www.mehvac.com

FORM# MSZ-GS12NA-U1 - 202304



# MXZ-3C30NA4 2.5-TON MULTI-ZONE INVERTER HEAT-PUMP SYSTEM



Job Name:

System Reference:

Date:

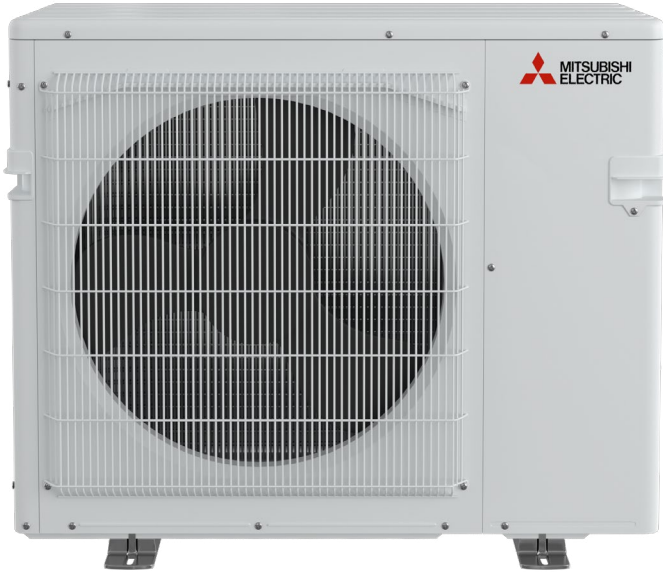

## FEATURES

- Variable speed INVERTER-driven compressor
- Optional base pan heater
- Quiet outdoor unit operation as low as 52 dB(A)
- High-pressure protection
- Compressor thermal protection
- Compressor overcurrent detection
- Fan motor overheating/voltage protection
- Blue Fin anti-corrosion treatment applied to the outdoor unit heat exchanger for increased coil protection and longer life
  - Rated for 2,000 hours spraying time per ASTM B117 Standard



# SPECIFICATIONS: MXZ-3C30NA4

	Type		R410A
Refrigerant	Pre-Charged Refrigerant Amount	Lbs, oz	6.0, 13.0
	Maximum Pre-Charged Piping Length	Ft. [m]	98.0 [30.0]
	Additional Refrigerant Charge Per Additional Piping Length	oz./Ft. [g/m]	0.216 [20]
Indoor unit connection	Maximum Number of Connected IDU		3
	Minimum Number of Connected IDU		2
	Minimum connected capacity	BTU/H	12,000
	Maximum connected capacity	BTU/H	36,000
Piping	Liquid Pipe Size O.D. (Flared)	In.[mm]	A,B,C: 1/4 [A,B,C: 6.35]
	Gas Pipe Size O.D. (Flared)	In.[mm]	A: 1/2; B,C: 3/8 [A: 12.72; B,C: 9.52]
	Total Piping Length	Ft. [m]	230 [70]
	Maximum Height Difference, ODU above IDU	Ft. [m]	49 [15]
	Maximum Height Difference, ODU below IDU	Ft. [m]	49 [15]
	Farthest Piping Length from ODU to IDU	Ft. [m]	82 [25]
	Maximum Number of Bends for IDU		70

**NOTES:**

AHRI Rated Conditions <sup>1</sup>Cooling (Indoor // Outdoor) °F 80 DB, 67 WB // 95 DB, 75 WB  
 (Rated data is determined at a fixed compressor speed) <sup>2</sup>Heating at 47°F (Indoor // Outdoor) °F 70 DB, 60 WB // 47 DB, 43 WB  
<sup>3</sup>Heating at 17°F (Indoor // Outdoor) °F 70 DB, 60 WB // 17 DB, 15 WB

Conditions <sup>4</sup>Heating at 5°F (Indoor // Outdoor) °F 70 DB, 60 WB // 5 DB, 4 WB

<sup>\*</sup>Applications should be restricted to comfort cooling only; equipment cooling applications are not recommended for low ambient temperature conditions.  
<sup>\*\*</sup>5°F DB - 115°F DB when optional wind baffles are installed

For actual capacity performance based on indoor unit type and number of indoor units connected, please refer to MXZ Operational Performance.  
 Although the maximum connectable capacity is 130%, the outdoor unit cannot provide more than 100% of the rated capacity. Please utilize this over capacity capability for load shedding or applications where it is known that all connected units will NOT be operating at the same time.

Low, mid and high external static pressure tests conducted at 0.1, 0.3 and 0.5 in.w.g. respectively, according to AHRI 210/240. The external static pressures utilized have no bearing on the capabilities of the indoor unit; please refer to the indoor unit manual to select the correct external static pressure setting for the application.

## OUTDOOR UNIT ACCESSORIES: MXZ-3C30NA4

Air Outlet Guide	Air Outlet Guide (1 Piece)	PAC-SH96SG-E
Ball Valve	Refrigeration Ball Valve - 1/2"	BV12FFSI2
	Refrigeration Ball Valve - 1/4"	BV14FFSI2
	Refrigeration Ball Valve - 3/8"	BV38FFSI2
	Refrigeration Ball Valve - 5/8"	BV58FFSI2
Control Wire	M-Net Control Wire, 1,000' Roll (16-AWG, Standard, Twisted Pair, Shielded, Jacketed- Plenum rated)	CW162S-1000
	M-Net Control Wire, 250' Roll (16-AWG, Standard, Twisted Pair, Shielded, Jacketed- Plenum rated)	CW162S-250
Drain Socket	Drain Socket	PAC-SG60DS-E
Hail Guards	Hail Guard	HG-A9
M-NET Converter	M-NET Converter	PAC-IF01MNT-E
Mini-Split Wire	14 Gauge, 4 wire MiniSplit Cable—250 ft. roll	S144-250
	14 Gauge, 4 wire MiniSplit Cable—250 ft. roll	SW144-250
	14 Gauge, 4 wire MiniSplit Cable—50 ft. roll	S144-50
	14 Gauge, 4 wire MiniSplit Cable—50 ft. roll	SW144-50
	16 Gauge, 4 wire MiniSplit Cable—250 ft. roll	S164-250
	16 Gauge, 4 wire MiniSplit Cable—250 ft. roll	SW164-250
	16 Gauge, 4 wire MiniSplit Cable—50 ft. roll	S164-50
	16 Gauge, 4 wire MiniSplit Cable—50 ft. roll	SW164-50
Mounting Pad	Condensing Unit Mounting Pad: 16" x 36" x 3"	ULTRILITE1
	Outdoor Unit 3-1/4 inch Mounting Base (Pair) - Plastic	DSD-400P
Port Adaptor	Adaptor: 1/2" x 3/8"	MAC-A455JP-E
	Adaptor: 1/2" x 5/8"	MAC-A456JP-E
	Adaptor: 3/8" x 1/2"	MAC-A454JP-E
	Adaptor: 3/8" x 5/8"	PAC-SG76RJ-E
Stand	18" Single Fan Stand	QSMS1801M
	24" Single Fan Stand	QSMS2401M
	Condenser Wall Bracket	QSWB2000M-1
	Condenser Wall Bracket - Stainless Steel Finish	QSWBSS
	Outdoor Unit Stand — 12" High	QSMS1201M

# OUTDOOR UNIT DIMENSIONS: MXZ-3C30NA4

Unit: inch (mm)

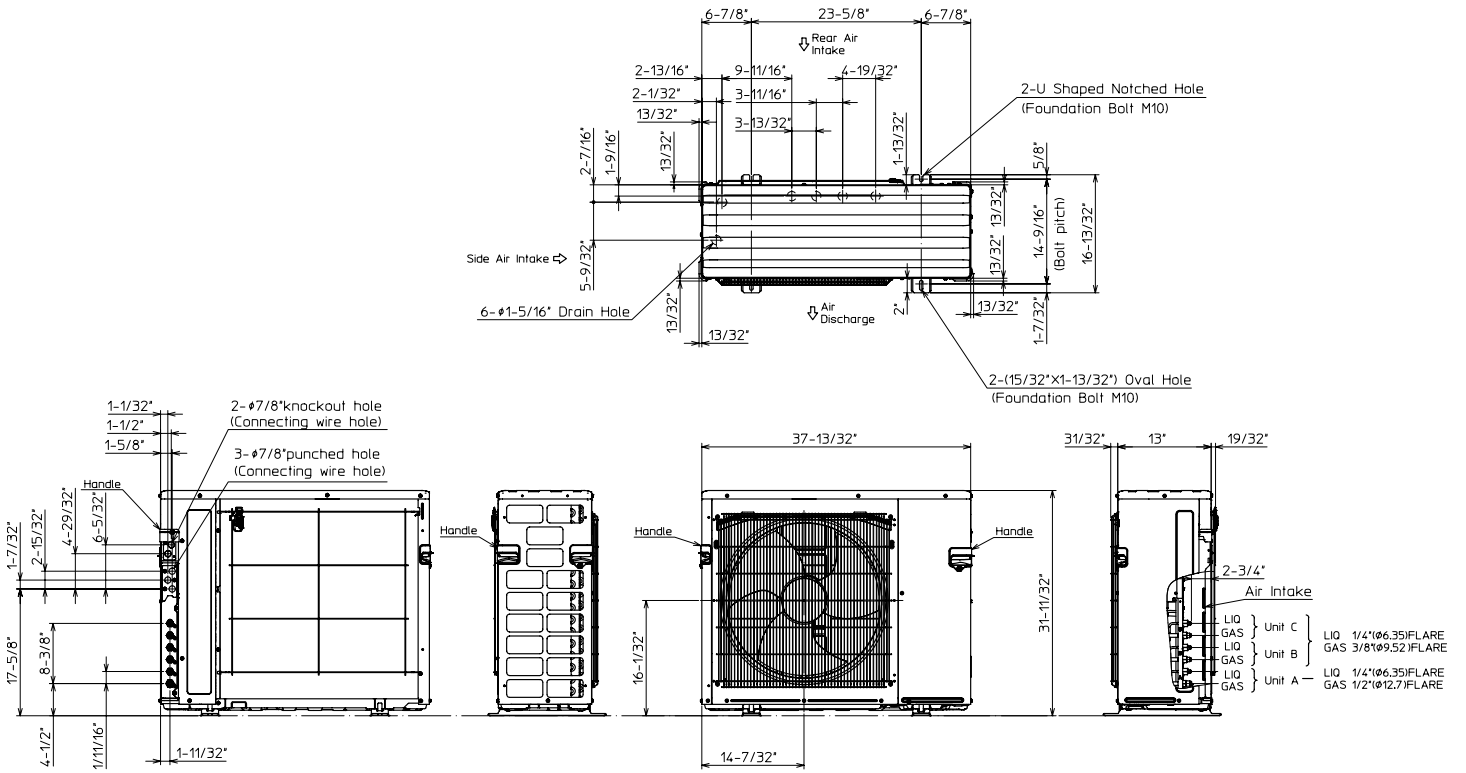

## 1.FREE SPACE

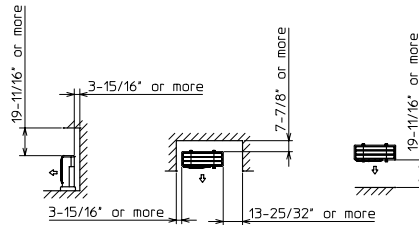

## 2.SERVICE SPACE

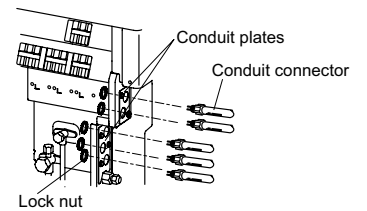
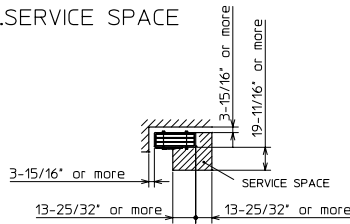

1340 Satellite Boulevard Suwanee, GA 30024  
 Toll Free: 800-433-4822 www.mehvac.com

FORM# MXZ-3C30NA4 - 202311



**Current processing time is 9 days (In review 9 days)**

Project Name:  [Add Note](#)

Project Description:

Permit Number: COA-25-0013      Applicant: Alonzo Adams

Initial Application Number: REFERENCE-25-0587      Primary Contact: Alonzo Adams <sup>i</sup>

Permit Type: CERTIFICATE OF APPROPRIATENESS- SIGNS      Primary Contractor:

Status\*:       Last Activity: 06/18/2025 09:07

Process State: Pending      Last Inspection Date:

Parent Permit:

Assigned To:        Initiated:

Fast Track:       Submitted\*:  Application is 10 days old

Applied for Online:       Completed:  4 of 5 submittals received, 4 of 5 submittals accepted.

Approved:  0 of 3 (0%) steps approved.

Ready:  \$0.00 paid (100%), \$0.00 due.

Issued:

Finalized:  No inspections.

Closed:  \$0.00 deferred fees due.

Expires:  Exp Override:

Site Address

Site Address:  [Verify Address and Coordinates](#)

Site City:       Latitude:

State:  Site Zip:       Longitude:

**Contact**

Contact    Phone Numbers    Email Addresses    Details    Secure Details    Points of Contact    Portal Accounts

[Replace Photo](#)

Contractor: No      Active:

First Name:       Middle Name:       Last Name:

Display Name\*:

Primary Phone: 4849251510      Primary Email: aadams@uptownventuregroup.com

Portal Access Code\*: AB7EL-8SYBI

Mailing Address

















18 Wilson Ave  
 West Chester, PA 19382

[Edit Address](#)

Physical Address

[Edit Address](#)    [Copy Mailing Address](#)

Permit #: COA-25-0013	Status: HARB REVIEW	Contact: Alonzo Adams	Site Address: 202 W GAY ST
Type: CERTIFICATE OF APPROPRIATENESS- SIGNS	Project Name: Business Sign & Front door	Contractor:	WEST CHESTER, PA 19380

Name	Value
REASON FOR APPROPRIATENESS APPLICATION:*	Sign 
LOCATION OF PROJECT:*	202 W Gay Street 
NAME OF BUSINESS:*	Revivéa 
ARE YOU REPLACING AN EXSISTING SIGN:*	No 
HOW MANY SIGNS DO YOU WISH TO INSTALL:*	1 
HOW MANY FACADES WILL SIGN DISPLAY ON:*	Front 
HANGING SIGN:	No 
BUILDING MOUNTED:	Yes 
OTHER:	
IF OTHER PLEASE SPECIFY:	
GIVE A THOROUGH DESCRIPTION OF SIGN:	Gray logo made of acrylic 
IS THERE NEW ILLUMINATION:	No 
FIXTURE TEXT:	Revivéa Health and Wellness 
SIGN DIMENSION HEIGHT:	84 
SIGN DIMENSION WIDTH:	10 
SIGN DIMENSION DEPTH:	1 

**APPLICATION FOR CERTIFICATE OF APPROPRIATENESS**

*Borough of West Chester*  
Historical and Architectural Review Board

**PROJECT ADDRESS:** 202 W. Gay Street

- 1) **Date of HARB Review:** June 26, 2025
- 2) **Applicant's Proposal:** Front Door Change and Sign
- 3) **Findings:**

*The applicant, Alonzo Adams of the Uptown Venture Group, was in attendance to present the project. The HARB previously reviewed and approved work to install a new storefront window and trim at this property under Application 2025-16. The current application is for installation of a new front entrance door and a new sign. The proposed project was described as follows:*

- *Install a new wood entrance door in the existing wood door frame. The existing transom window above will be retained.*
- *The current door design documents were submitted at the meeting as a 3/4 single-lite door with a 1/4 height recessed lower wood panel. Home Depot, Builder's Choice brand, 36x80 inch, Model #RV4621FIRCLI30*
- *The new sign is to be acrylic individual letters, pin-mounted to the new Azek frieze panel above the new storefront window.*
- *The message of the sign is "REVIVEA – Health and Wellness"*
- *No lighting for the sign is proposed or included in the application.*

*The HARB reviewed the application in detail and made the following comments:*

- *Ms. Quigley stated that originally the proposed door was full-glass, but was revised by the applicant to the 3/4 -lite design as presented in the supplemental documents submitted at the meeting.*
- *The HARB found the current door design to be appropriate.*
- *The HARB commented that the sign design was appropriate, the final sign size should be adjusted as needed to fit within the existing wall panel.*
- *No sign lighting is currently planned. The HARB commented that halo-lit individual sign letters or exterior gooseneck- type lighting fixtures may be acceptable. The applicant would need to provide full details for future review and approval.*
- *Brick wall repairs above the front door should use the existing brick salvaged from the installation of the new storefront window.*

4) **Recommendations from HARB:**

*The Board recommends Approval of a Certificate of Appropriateness for Application 2025-21 as submitted, including the revised door specification document provided at the June 26 HARB meeting, with the following clarifications:*

1. *The front door will be wood, 3/4-lite, with a 1/4-height recessed wood lower panel as presented at the meeting.*
2. *The sign design is approved as submitted. Final sign size shall be adjusted to fit within the new frieze panel above the storefront window as illustrated on the drawings.*
3. *The brick wall above the door, following door hood removal, shall be repaired and restored to match the existing brick and mortar joint construction.*

Application Numbers: [2025-21](#)

**APPLICATION FOR CERTIFICATE OF APPROPRIATENESS**  
*Borough of West Chester*  
Historical and Architectural Review Board

PROJECT ADDRESS: 202 W. Gay Street

**5) Borough Council's Action and Date**

- Approved per HARB recommendation:
- Denied for the following reasons:
- Approved with the following differences from HARB recommendation:

.....

Date of Action Taken: \_\_\_\_\_, 2025

Borough Manager's Signature:

202 Site/Grade

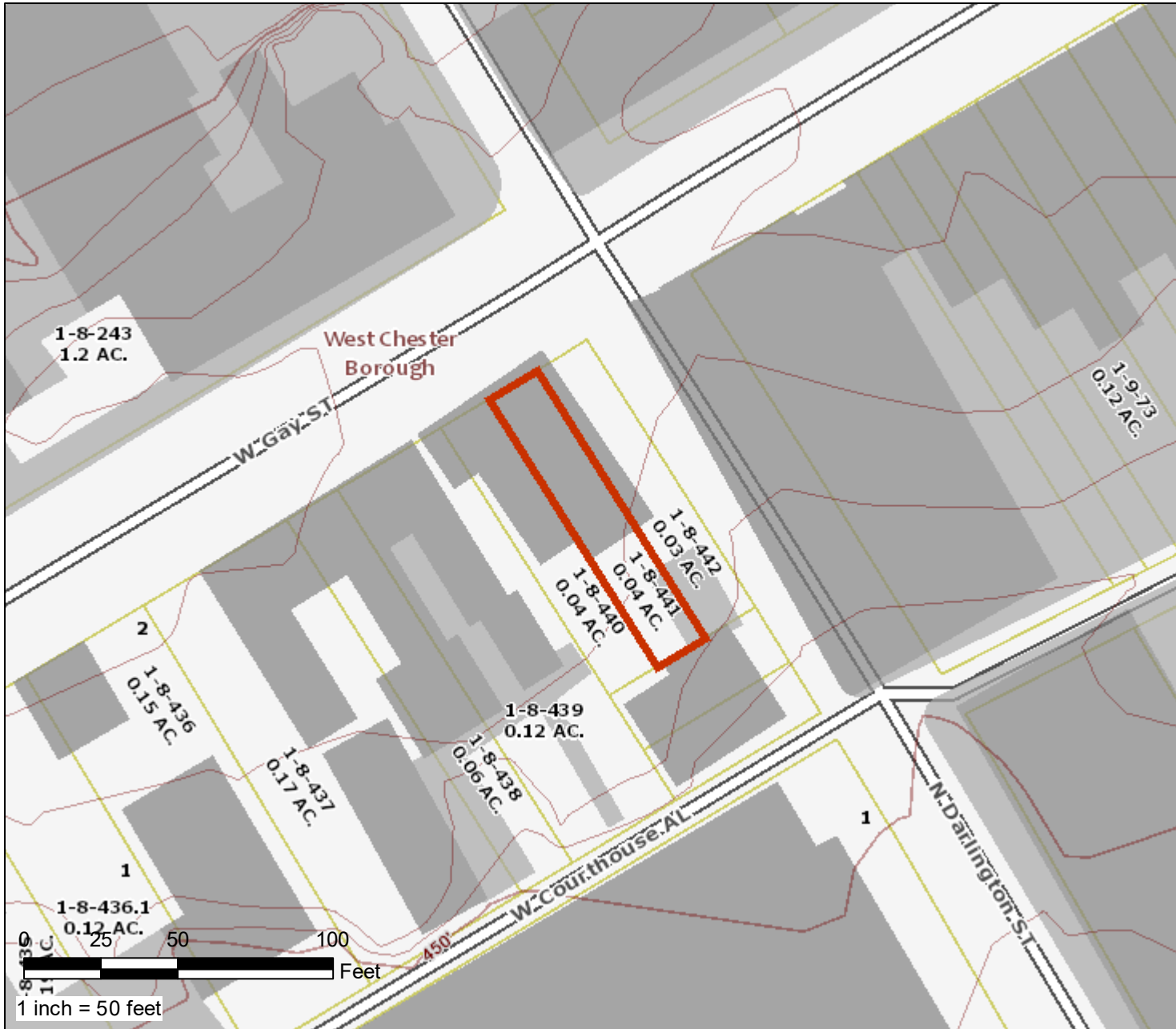

COUNTY OF CHESTER  
PENNSYLVANIA

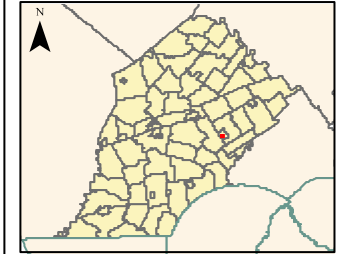

Find Address Information

PARID: 0108 044 1000  
 UPE: 1-8-441  
 Owner1: UPTOWN VENTURE GROUP LLC  
 Owner2:  
 Mail Address 1: 18 WILSON AVE  
 Mail Address 2: WEST CHESTER PA  
 Mail Address 3:  
 ZIP Code: 19382  
 Deed Book: 11087  
 Deed Page: 890  
 Deed Recorded Date: 07/28/2023  
 Legal Desc 1: SS OF W GAY ST  
 Legal Desc 2: LOT & APTS  
 Acres: 0.0375  
 LUC: R-20  
 Lot Assessment: 30710  
 Property Assessment: 47820  
 Total Assessment: 78530  
 Assessment Date: 12/15/2023 7:39:35 AM  
 Property Address: 202 W GAY ST  
 Municipality: WEST CHESTER  
 School District: West Chester Area

Map Created:  
 Tuesday, March 19, 2024



County of Chester

**Limitations of Liability and Use:**  
 County of Chester, Pennsylvania makes no claims to the completeness, accuracy, or content of any data contained herein, and makes no representation of any kind, including, but not limited to, the warranties of merchantability or fitness for a particular use, nor are any such warranties to be implied or inferred with respect to the information or data furnished herein. For information on data sources visit the GIS Services page listed at [www.chesco.org/gis](http://www.chesco.org/gis).



202

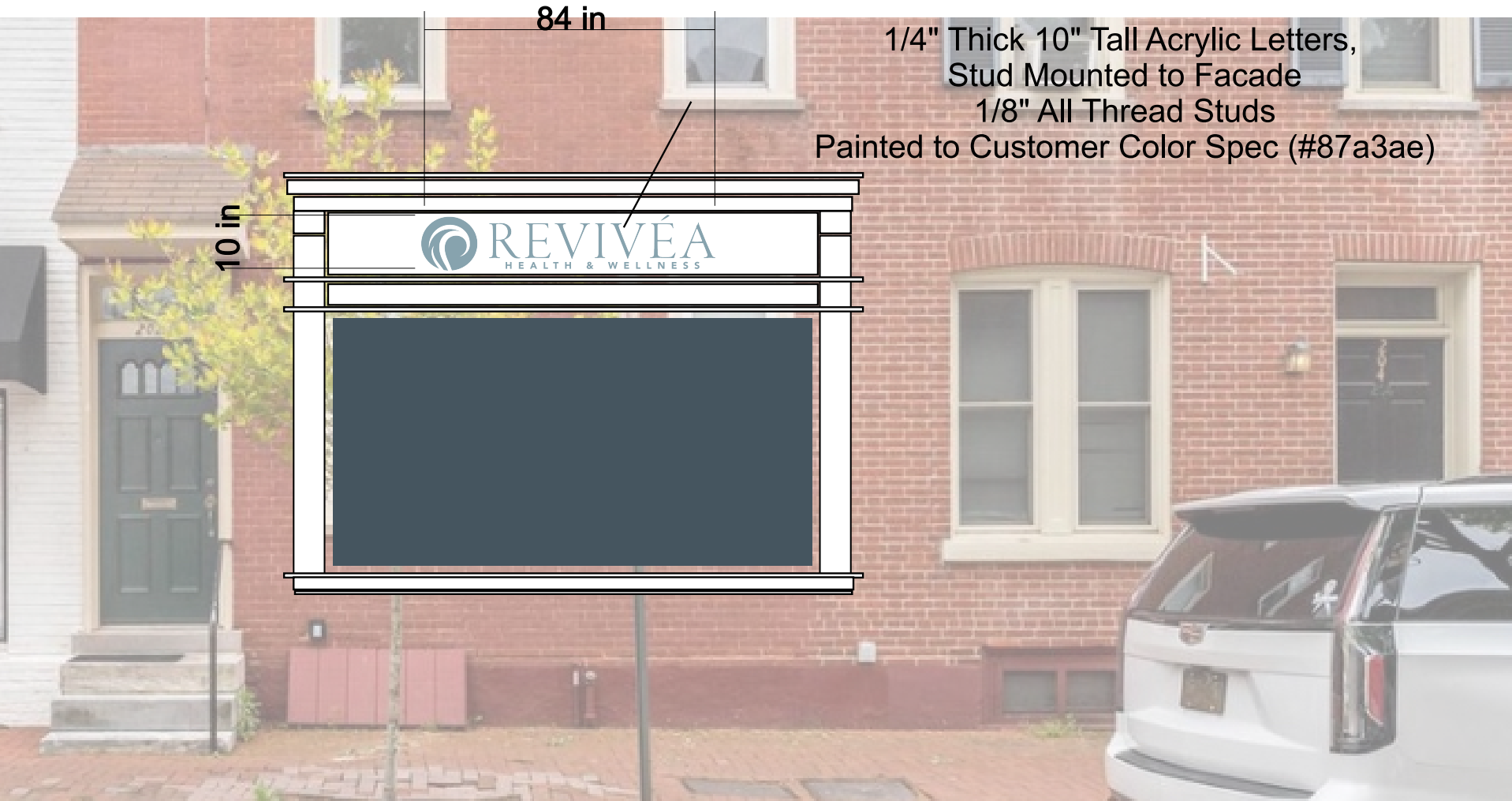

84 in

10 in

1/4" Thick 10" Tall Acrylic Letters,  
Stud Mounted to Facade  
1/8" All Thread Studs  
Painted to Customer Color Spec (#87a3ae)

REVIVÉA  
HEALTH & WELLNESS

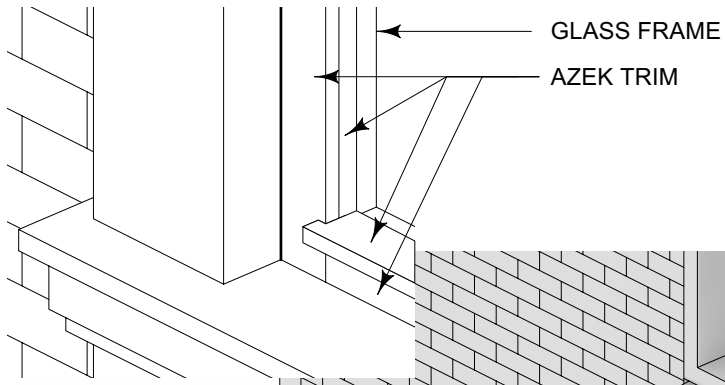

5

**CORNER DTL**  
Scale: 1 1/2" = 1'-0"

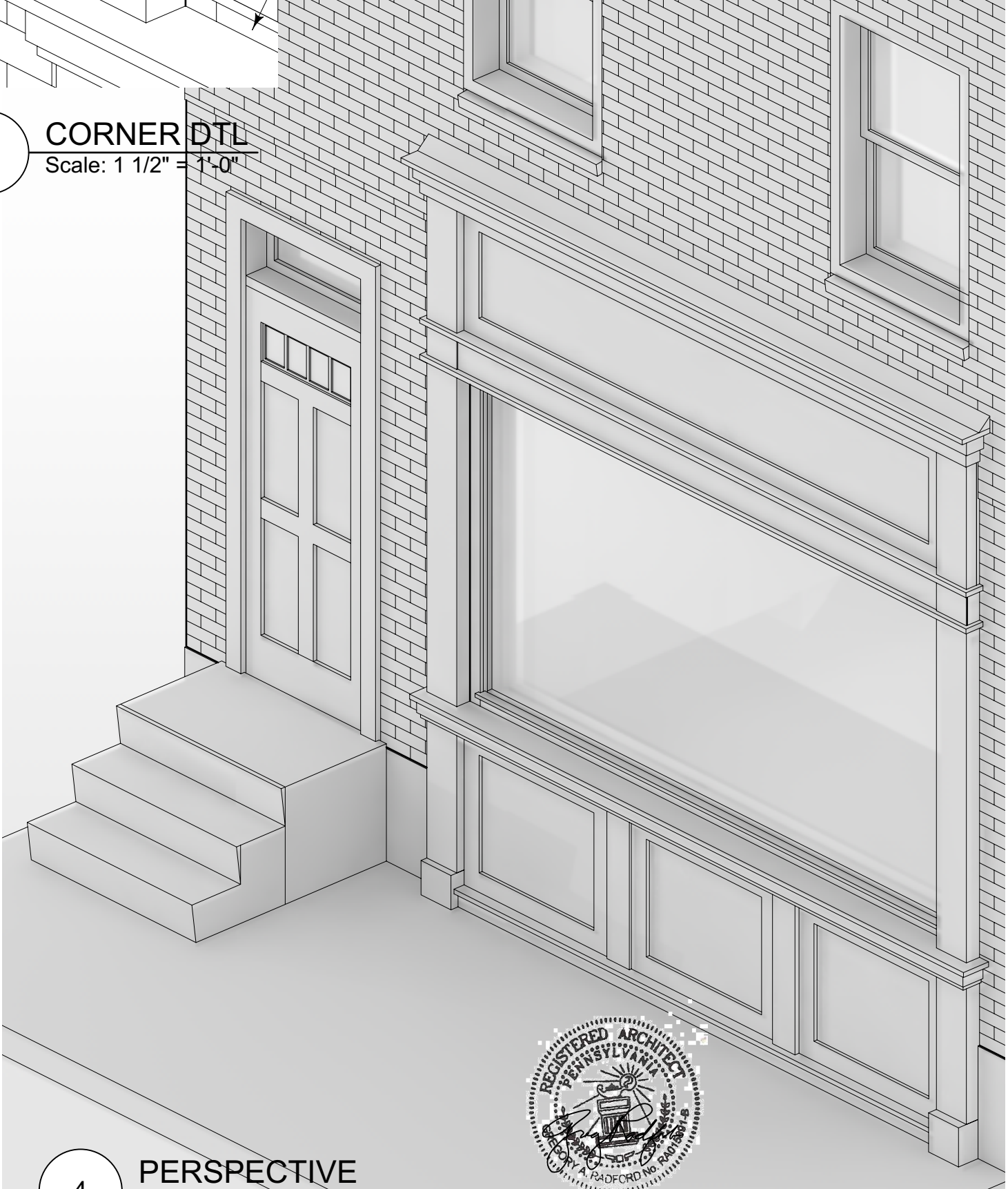

4

**PERSPECTIVE**  
Scale: 1/2" = 1'-0"





Gawthrop Greenwood, PC  
*Attorneys at Law*

17 East Gay Street, Suite 100, P.O. Box 562 p. 610.696.8225  
West Chester, PA 19381-0562 www.gawthrop.com

**James D. Doyle**  
610.696.8225 x.1743  
jdoyle@gawthrop.com

June 11, 2025

Sean Metrick, Borough Manager  
Borough of West Chester  
401 East Gay Street  
West Chester, PA 19380

Re: Zoning Hearing Board Application

Dear Mr. Metrick:

As you will recall, I represent Daniel A. Hollander and Melissa Jean Hollander (“Applicants”). Attached please find an amended Zoning Hearing Board Application for the parcel located at 531 Marshall Drive (UPI No. 1-2-89), located in the NC-1 Neighborhood Conservation District of West Chester Borough, along with an amended Plan.

A check for the required continuance fee of \$200.00 will be delivered to Borough Hall, per Wendy Mecke’s instruction. Thank you for your consideration of this matter.

Very truly yours,  
**GAWTHROP GREENWOOD, PC**

  
James D. Doyle



# Borough of West Chester

401 East Gay Street ▪ West Chester, Pennsylvania ▪ 19380

Telephone: 610-692-7574 ▪ Facsimile: 610-436-0009

[www.west-chester.com](http://www.west-chester.com)

## ZONING HEARING BOARD APPLICATION

APPEAL # \_\_\_\_\_ DATE RECEIVED \_\_\_\_\_

Property (real estate) Location 531 Marshall Drive

Zoning District: NC-1 Neighborhood Conservation District Tax Parcel: 1-2-89

I / We (name) Daniel and Melissa Hollander of (address) 531 Marshall Drive request the scheduling of a hearing on it/my/our APPEAL (Application) to the West Chester Borough Zoning Hearing Board on the following grounds: (choose one or more):

**Special Exception** to the Borough of West Chester Zoning Ordinance of 2021 (cite Ordinance Sections), specifically:

\_\_\_\_\_  
\_\_\_\_\_

**Variance** to the Borough of West Chester Zoning Ordinance of 2021 (cite Ordinance Sections), specifically:

§112-306.B (Dimensional Requirements)

§112-602L (General Regulations and Design Standards)

§112-602K (Parking in Front of Building)

**Appeal** a decision of the Zoning Officer, Specifically, the following:

\_\_\_\_\_  
\_\_\_\_\_

**Other** \_\_\_\_\_

Application Received By: \_\_\_\_\_

Date: \_\_\_\_\_

### **NOTICE**

Please see the Borough's website for the Fee Schedule for Zoning Fees. Zoning Fees are not refundable upon the Zoning Hearing scheduling and holding a hearing. A hearing will be scheduled only upon submission of a complete Application and payment of the applicable fee.



## Borough of West Chester

401 East Gay Street ▪ West Chester, Pennsylvania ▪ 19380

Telephone: 610-692-7574 ▪ Facsimile: 610-436-0009

[www.west-chester.com](http://www.west-chester.com)

A) The description of the Property (real estate located in West Chester Borough) including acreage (square feet), current improvements and use:

The property is approximately 0.2357 acres in area, and is improved with a single-family detached dwelling and driveway. The use is residential.

B) a) Does the Applicant own the Property? (  ) Yes ( ) No

b) If "NO", who is the Owner of the Property? \_\_\_\_\_

c) If not the Owner, what is your legal authority (e.g. – equitable owner, tenant, etc.) for filing this Application on behalf of Owner? \_\_\_\_\_

C) I/We believe that the Zoning Hearing Board should approve this request because: (Please include the grounds for appeal or reasons both with respect to the law and fact in support of your relief request for the Appeal or Special Exception or Variance. You may also attach your explanation in a separate narrative including any documents supporting your request).

Please see attached narrative.

( X ) See Attached Narrative

D) Has any previous application or appeal been filed in connection with this Property?

( ) Yes ( X ) No

### (E) PLOT PLAN REQUIREMENTS (Supporting Documents)

A Plot Plan of the Property must be submitted as part of this Application. The plot plan shall contain a description of this Property (lot) and show all of the information as follows:

1. Length of all Property (lot) lines.
2. Approximate acres or square feet of Property.
3. Show location of all buildings/structures on Property, their outside dimensions, the distances between buildings and the Property's boundaries.



# Borough of West Chester

401 East Gay Street ▪ West Chester, Pennsylvania ▪ 19380

Telephone: 610-692-7574 ▪ Facsimile: 610-436-0009

[www.west-chester.com](http://www.west-chester.com)

4. If this application is for new buildings or additions to present buildings, show these proposed buildings/additions giving outside dimensions and the distances between any new structures and existing buildings plus distances between any proposed buildings and the Property's boundaries.
5. Show any existing roads or driveways on the Property and the location of any new drives (if any) you plan to construct.
6. Show location and sizes of all existing parking spaces on the Property and additionally, if any, parking spaces you plan to construct.

**NOTE:** This Application must be completed in full and submitted with Supporting Documents. Two (2) copies of the Application, the Plot Plan and any supporting documents are required as part of your submission. Please also submit the Application and Supporting Documents in a PDF to [Housing@west-chester.com](mailto:Housing@west-chester.com)

\*\*\*\*\*

The Applicant certifies that the above statements contained in this Application and Supporting Documents submitted are true and correct to the best of its/my/our knowledge and belief.

Daniel and Melissa Hollander

Name of Applicant(s)

Signature, James Doyle, Esq., Attorney for Applicants

531 Marshall Drive, West Chester, PA 19380

Address of Applicant

Phone Number

Email Address (if any)

Daniel and Melissa Hollander

Name of Applicant(s)

6/11/2025

Date

James D. Doyle, Esquire  
Attorney (If Represented)

17 East Gay St, Suite 100  
West Chester, PA 19381-0562

610-696-8225;  
jdoyle@gawthrop.com

Phone or Email

\*\*\*\*\*

### Borough Use Only

Zoning Hearing Board Fee: \_\_\_\_\_ Check No.: \_\_\_\_\_ Date Received: \_\_\_\_\_

Received By: \_\_\_\_\_

Borough Employee

**Zoning Hearing Board Application of  
Daniel A. Hollander and Melissa Jean Hollander**

**Property Information**

Address: 531 Marshall Drive (UPI No. 1-2-89)  
Owners: Daniel A. Hollander and Melissa Jean Hollander  
Lot Area: 0.2357 acres  
Zoning District: NC-1 Neighborhood Conservation District

Daniel A. Hollander and Melissa Jean Hollander (hereinafter "Applicants") respectfully file this zoning hearing board application with the West Chester Borough Zoning Hearing Board (hereinafter "Board"). The subject property is UPI No. 1-2-89, on Marshall Drive in the NC-1 Neighborhood Conservation District (hereinafter "Property").

The Property is owned by Applicants as husband and wife. The Property is used by Applicants as their primary residence and is currently improved with one single-family dwelling and driveway. The Property does not have a garage, which limits the Applicants' ability to securely store vehicles and other personal property.

The Applicants seek to construct a one-story attached garage attached to the existing single-family detached dwelling that will be approximately 533 square feet in size, and corresponding driveway extension.

**Variance Request**

**The Applicants are seeking a variance from Section 112-306.B (dimensional requirements) of the West Chester Borough Zoning Ordinance to permit the construction of a one-story attached garage that will encroach approximately 12.6 feet into the 15 foot required side yard setback.**

**The Applicants are also seeking a variance from Section 112-306.B (dimensional requirements) and Section 112-602.L (General regulations and design standards) to permit the construction of a corresponding driveway extension that will encroach approximately 3.7 feet into the 5 foot required side yard setback for an accessory structure and parking spaces.**

**Additionally, the Applicants seek a variance from Section 112-602.K (Parking in front of building ) to permit parking spaces to be located within the required front yard.**

**The Property will otherwise comply with all applicable area and bulk regulations, including existing nonconforming conditions, such as minimum lot area, minimum lot width, minimum front yard setback, minimum rear yard**

setback, minimum rear yard setback for accessory structures, maximum building coverage, maximum impervious coverage, and maximum building height.





# Borough of West Chester

401 East Gay Street ▪ West Chester, Pennsylvania ▪ 19380

Telephone: 610-692-7574 ▪ Facsimile: 610-436-0009

[www.west-chester.com](http://www.west-chester.com)

## ZONING HEARING BOARD APPLICATION

APPEAL # **1031**

DATE RECEIVED **06/10/2025**

Property (real estate) Location 501 E. Miner Street, West Chester, PA 19382

Zoning District: Commercial Service (CS)

Tax Parcel: 1-5-478.1 and 1.5.478-E

I / We (name) Charles A. Melton Arts & Education Center of (address) 501 E. Miner Street, West Chester, PA 19382 request the scheduling of a hearing on it/my/our APPEAL (Application) to the West Chester Borough Zoning Hearing Board on the following grounds: (choose one or more):

**Special Exception** to the Borough of West Chester Zoning Ordinance of 2021 (cite Ordinance Sections), specifically:

\_\_\_\_\_  
\_\_\_\_\_  
\_\_\_\_\_

**Variance** to the Borough of West Chester Zoning Ordinance of 2021 (cite Ordinance Sections), specifically:

112-702.B(2)(o)(8)

\_\_\_\_\_  
\_\_\_\_\_  
\_\_\_\_\_

**Appeal** a decision of the Zoning Officer, Specifically, the following:

\_\_\_\_\_  
\_\_\_\_\_  
\_\_\_\_\_

Other \_\_\_\_\_

\_\_\_\_\_

Application Received By: W. Mecke

Date: 06/10/2025

### **NOTICE**

Please see the Borough's website for the Fee Schedule for Zoning Fees. Zoning Fees are not refundable upon the Zoning Hearing scheduling and holding a hearing. A hearing will be scheduled only upon submission of a complete Application and payment of the applicable fee.



## Borough of West Chester

401 East Gay Street ▪ West Chester, Pennsylvania ▪ 19380

Telephone: 610-692-7574 ▪ Facsimile: 610-436-0009

[www.west-chester.com](http://www.west-chester.com)

A) The description of the Property (real estate located in West Chester Borough) including acreage (square feet), current improvements and use:

The Property is 2.2 acres and is currently used as a non-profit community center, providing civic, arts, recreation and education programs in the Borough of West Chester.

---

---

---

B) a) Does the Applicant own the Property?  Yes ( ) No

b) If "NO", who is the Owner of the Property? \_\_\_\_\_

---

c) If not the Owner, what is your legal authority (e.g. – equitable owner, tenant, etc.) for filing this Application on behalf of Owner? \_\_\_\_\_

---

C) I/We believe that the Zoning Hearing Board should approve this request because: (Please include the grounds for appeal or reasons both with respect to the law and fact in support of your relief request for the Appeal or Special Exception or Variance. You may also attach your explanation in a separate narrative including any documents supporting your request).

The Applicant is proposing to install a 4' X 8' (32 sq. ft) X 6' tall single-sided sign, with a 24 Sq. ft. LED message board. This is located 465' from the Franklin Mint Fed. Credit Union changeable sign, and the ordinance requires 500' distance.

---

---

---

See Attached Narrative

D) Has any previous application or appeal been filed in connection with this Property?

( ) Yes (●) No

### (E) PLOT PLAN REQUIREMENTS (Supporting Documents)

A Plot Plan of the Property must be submitted as part of this Application. The plot plan shall contain a description of this Property (lot) and show all of the information as follows:

1. Length of all Property (lot) lines.
2. Approximate acres or square feet of Property.
3. Show location of all buildings/structures on Property, their outside dimensions, the distances between buildings and the Property's boundaries.



# Borough of West Chester

401 East Gay Street ▪ West Chester, Pennsylvania ▪ 19380

Telephone: 610-692-7574 ▪ Facsimile: 610-436-0009

[www.west-chester.com](http://www.west-chester.com)

4. If this application is for new buildings or additions to present buildings, show these proposed buildings/additions giving outside dimensions and the distances between any new structures and existing buildings plus distances between any proposed buildings and the Property's boundaries.
5. Show any existing roads or driveways on the Property and the location of any new drives (if any) you plan to construct.
6. Show location and sizes of all existing parking spaces on the Property and additionally, if any, parking spaces you plan to construct.

**NOTE:** This Application must be completed in full and submitted with Supporting Documents. Two (2) copies of the Application, the Plot Plan and any supporting documents are required as part of your submission. Please also submit the Application and Supporting Documents in a PDF to [Housing@west-chester.com](mailto:Housing@west-chester.com)

\*\*\*\*\*

The Applicant certifies that the above statements contained in this Application and Supporting Documents submitted are true and correct to the best of its/my/our knowledge and belief.

Charles A. Melton Arts & Education Center

Name of Applicant(s)

Signature Brian L. Nagle, Esquire Attorney-in-Fact  
Robert M. Tucker, Esquire Attorney-in-Fact  
501 E. Miner Street, West Chester, PA 19382

Address of Applicant

Phone Number

Email Address (if any)

Name of Applicant(s)

June 10, 2025

Date  
Brian L. Nagle, Esquire  
Robert M. Tucker, Esquire

Attorney (If Represented)  
17 W. Miner Street, P.O. Box 660  
West Chester, PA 19381-0660

Address  
[bnagle@macelree.com](mailto:bnagle@macelree.com)  
[rtucker@macelree.com](mailto:rtucker@macelree.com)

Phone or Email 610-436-0100

\*\*\*\*\*

### Borough Use Only

Zoning Hearing Board Fee: \_\_\_\_\_ Check No.: \_\_\_\_\_ Date Received: \_\_\_\_\_

Received By: \_\_\_\_\_  
Borough Employee



## Borough of West Chester

401 East Gay Street ▪ West Chester, Pennsylvania ▪ 19380

Telephone: 610-692-7574 ▪ Facsimile: 610-436-0009

[www.west-chester.com](http://www.west-chester.com)

Zoning Officer Review:

---

Signature: \_\_\_\_\_

Date: \_\_\_\_\_

**NARRATIVE IN SUPPORT OF APPLICATION FOR VARIANCE**

**I. Introduction**

The Charles A. Melton Arts & Education Center (“**Applicant**”) is the owner of a certain 2.2-acre parcel of real property in West Chester Borough (“**Borough**”), UPI No. 1-5-478 (“**Property**”).

**II. Request for Relief**

Applicant is planning to install a sign with an overall dimension of 48 inches by 96 inches, the changeable portion of the sign to be 36 inches by 96 inches with the sign to be 72 from the ground (“**Proposed Sign**”). A copy of the plan by KC Sign & Awnings is attached to the Application.

The proposed sign is classified as a “changeable-copy sign” in the Borough’s Zoning Ordinance. Under the Borough’s Zoning Ordinance, no changeable-copy sign is permitted within 500 feet of another. See Zoning Ordinance §112-702.B(2)(o). The Proposed Sign is located 465 feet from the Franklin Mint Federal Credit Union changeable copy sign at 400 E. Market Street.

Therefore, the Applicant is seeking a variance from Section 112-702.B(2)(o) to permit the Proposed Sign to be located 465 feet from the Franklin Mint Federal Credit Union change-able copy sign.

At the hearing, Applicant will demonstrate that it will comply with all other zoning regulations applicable to the Proposed Sign. The Applicant is requesting a 7% deviation from the Zoning Ordinance, which may constitute as a *de minimis* variance.

Applicant will further demonstrate compliance with the general requirements for variances at Section 112-1105.C of the Zoning Ordinance. This includes, but it not limited to, Applicant demonstrating that the Proposed Sign will not alter the essential character of the neighborhood, nor will it be detrimental to the public welfare.

### III. Conclusion

Applicant will present testimony and evidence in support of the requested variance and establish compliance with all other applicable Ordinance standards during the hearing before the Zoning Hearing Board.

Respectfully submitted,

**MacELREE HARVEY, LTD.**



By:

---

Brian L. Nagle, Esquire  
Robert M. Tucker, Esquire  
MacElree Harvey, Ltd.  
17 W. Miner Street  
West Chester, PA 19381  
610-436-0100  
*Attorneys for Applicant*

Date: June 10, 2025

June 10, 2025

**Via Hand Delivery**

West Chester Borough Council  
Attn: Sean Metrick, Borough Manager  
401 East Gay Street  
West Chester, PA 19380

**Re: Application for Variance of Charles A. Melton Arts & Education Center**

Dear Sean:

I am submitting on behalf of my client, Charles A. Melton Arts & Education Center five (5) copies of the following:

- Application for Variance;
- Narrative in Support of Application;
- Distance Between Signs from KC Signs
- Sign Specs Revised
- Site Plan
- Electronic copy of the above Application
- Application fee of \$800.00

Please let me know if you require additional physical copies of any materials.

Very truly yours,



Brian L. Nagle

/cfg

Enclosures

cc: Nathan M. Cline, P.E., Borough Engineer (w/enclosures) *[via Electronic Mail Only]*  
Kristin S. Camp, Esquire, Solicitor (w/enclosures) *[via Electronic Mail Only]*  
Mike Barbieri, Zoning Officer (w/enclosures) *[via Electronic Mail Only]*  
Charles A. Melton Arts & Education Center Education (w/enclosures) *[via Electronic Mail Only]*



- A** Existing Franklin Mint Federal Credit Union changeable copy sign
- B** Proposed Charles A. Melton Arts & Education Center changeable copy sign

 <p><b>Design • Build • Installation • Service</b></p>	<b>CUSTOMER NAME</b>	Sign Description:	<b>DATE</b>	<b>CONTACT</b>	
	Charles A. Melton Arts and Education		1/17/25	Greg Feld	
	<b>SITE ADDRESS</b>		<b>KC SIGN COMPANY</b>		
	501 East Miner Street West Chester, PA 19382		142 Conchester Hwy Aston, PA 19014 Ph: 610-497-0111 Fax: 610-497-0110 E-mail - gfeld@kcsignco.com		
<b>ORDER NUMBER</b>	<b>PAGE NUMBER</b>				
081904	3	THIS IS AN ORIGINAL UNPUBLISHED DRAWING, CREATED BY KC SIGN CO. IT IS SUBMITTED FOR YOUR APPROVAL, IN CONNECTION WITH A PROJECT BEING PLANNED BY KC SIGN CO. IT IS FOR YOUR EXCLUSIVE USE, IT IS NOT TO BE USED, REPRODUCED, COPIED OR EXHIBITED IN ANY FASHION. THIS DRAWING IS PROPERTY OF KC SIGN CO.	*NOTE* DUE TO VARIANCES AMONG COLOR PRINTED & COMPUTER MONITORS THE COLORS YOU SEE ON YOUR PROOF MAY NOT BE THE EXACT COLORS OF OUR PRODUCTS. THE COLORS YOU SEE SHOULD BE CONSIDERED CLOSE RENDITIONS TO THE ACTUAL COLORS AVAILABLE.		

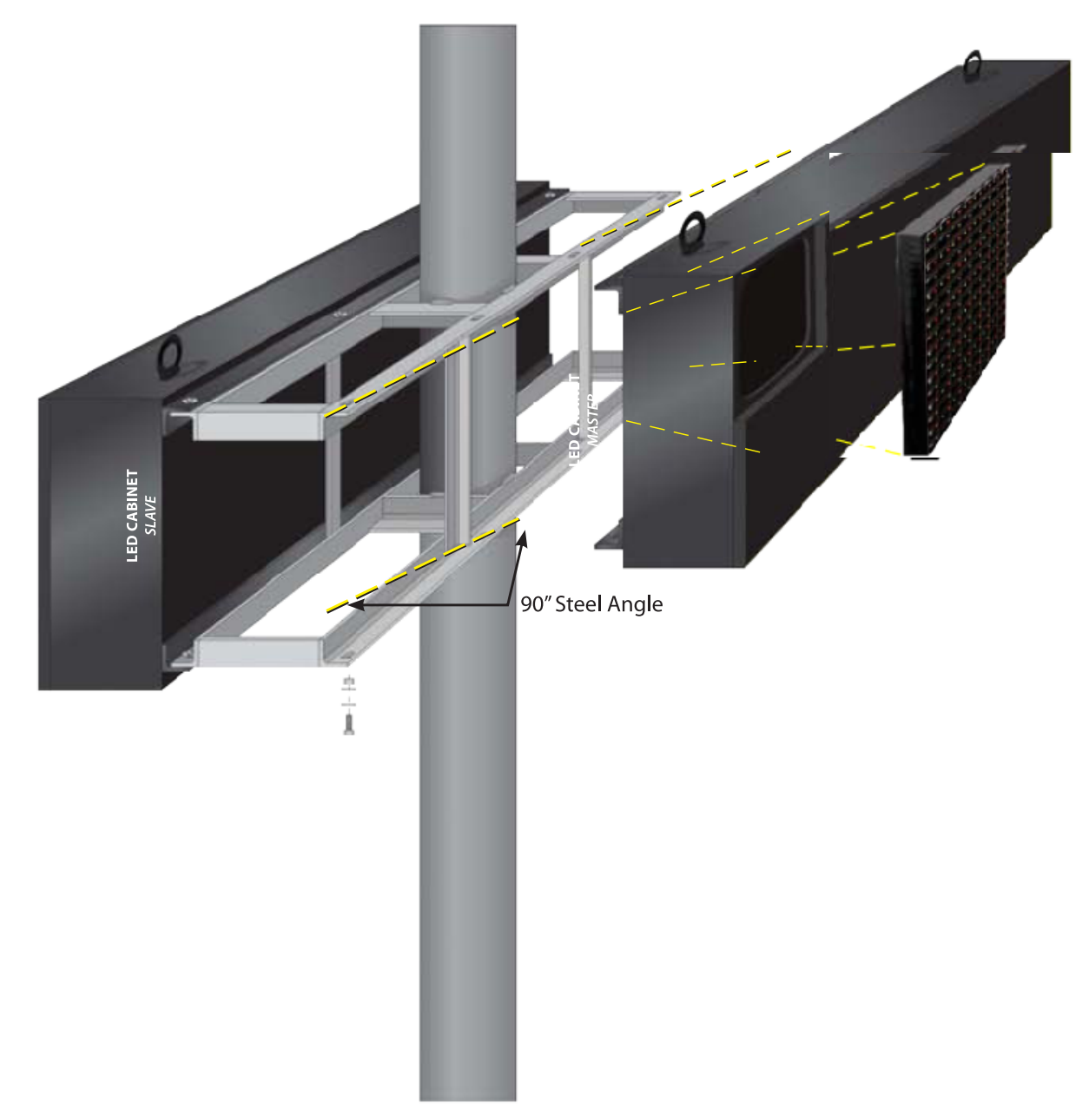
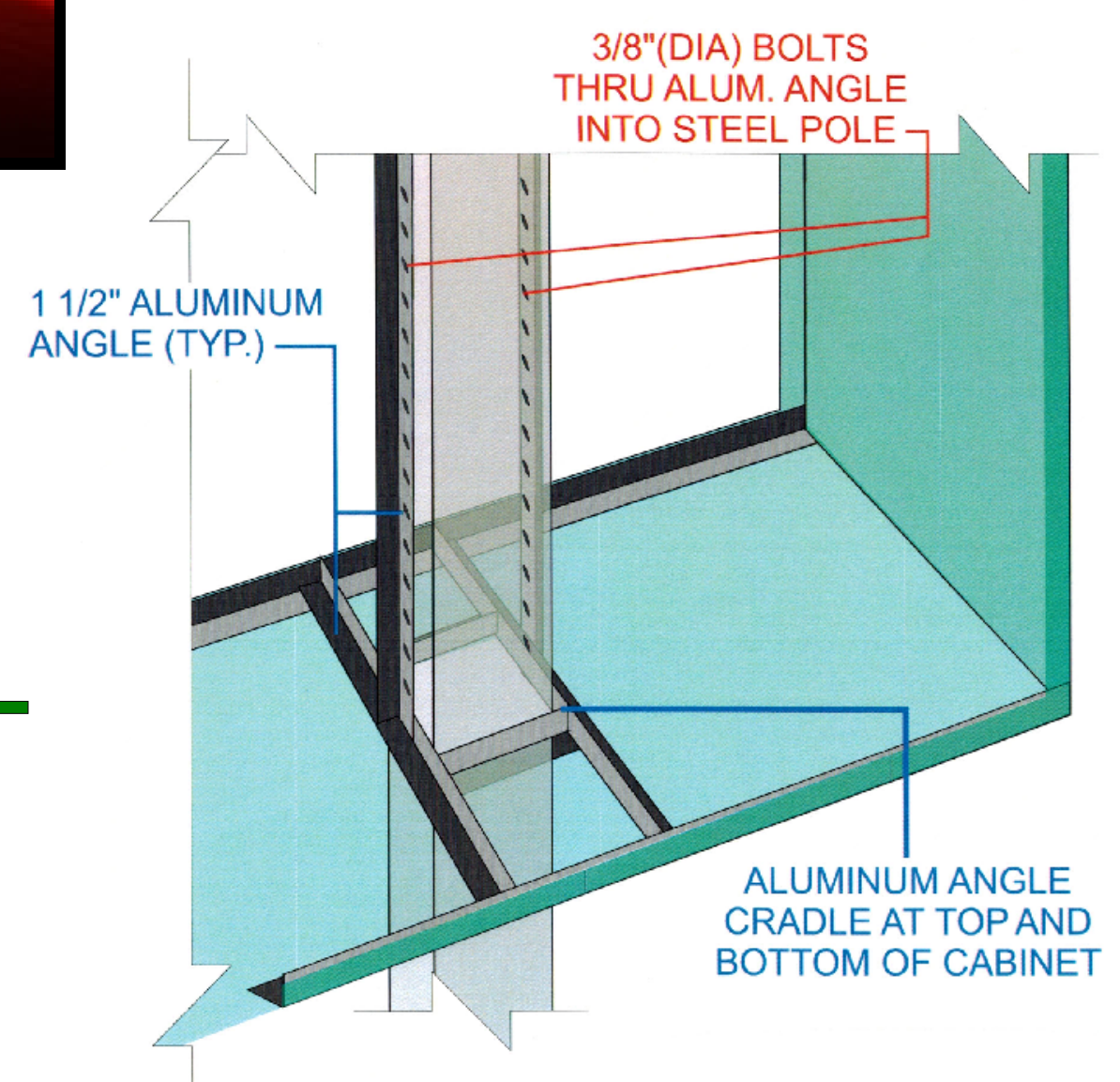
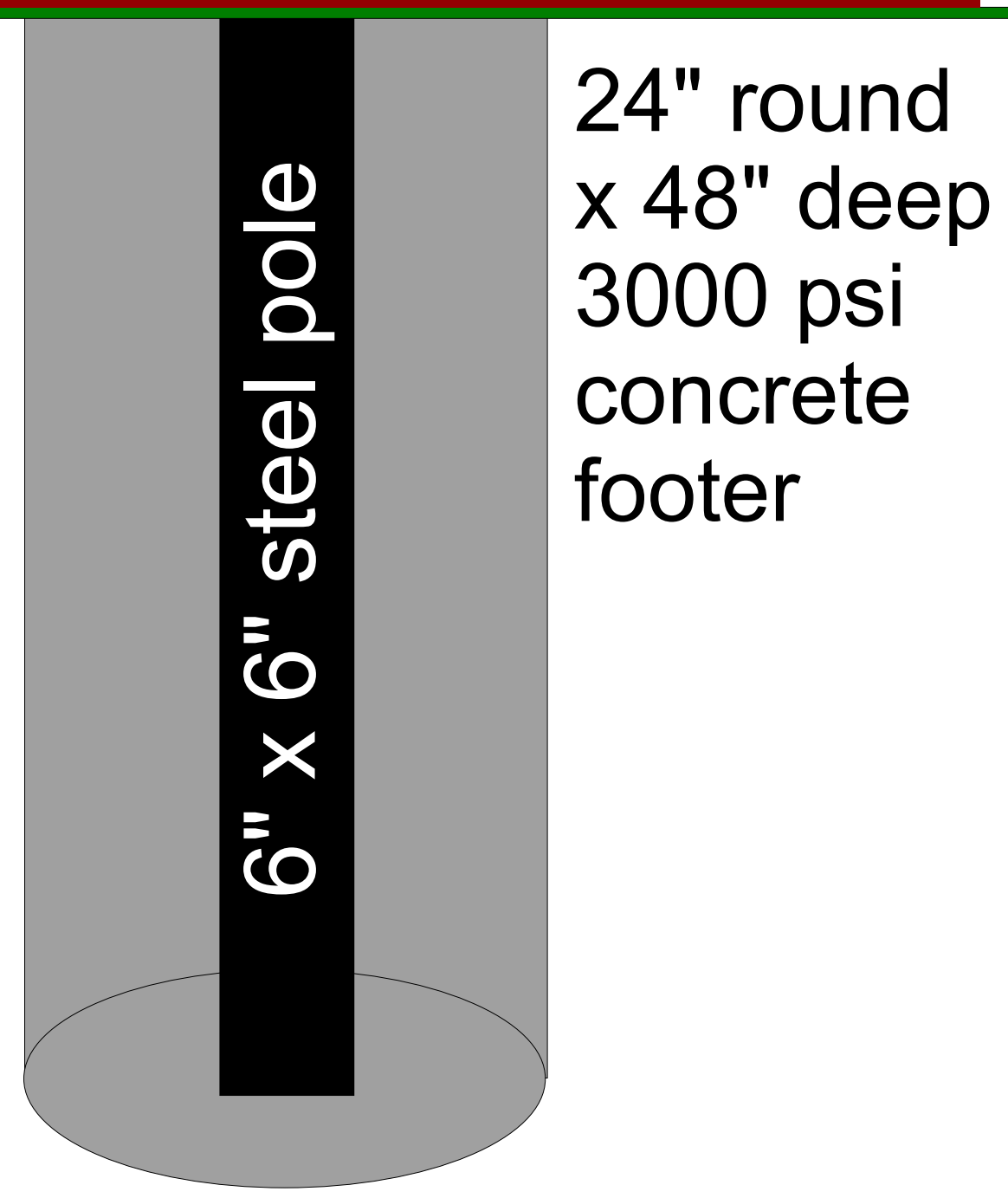
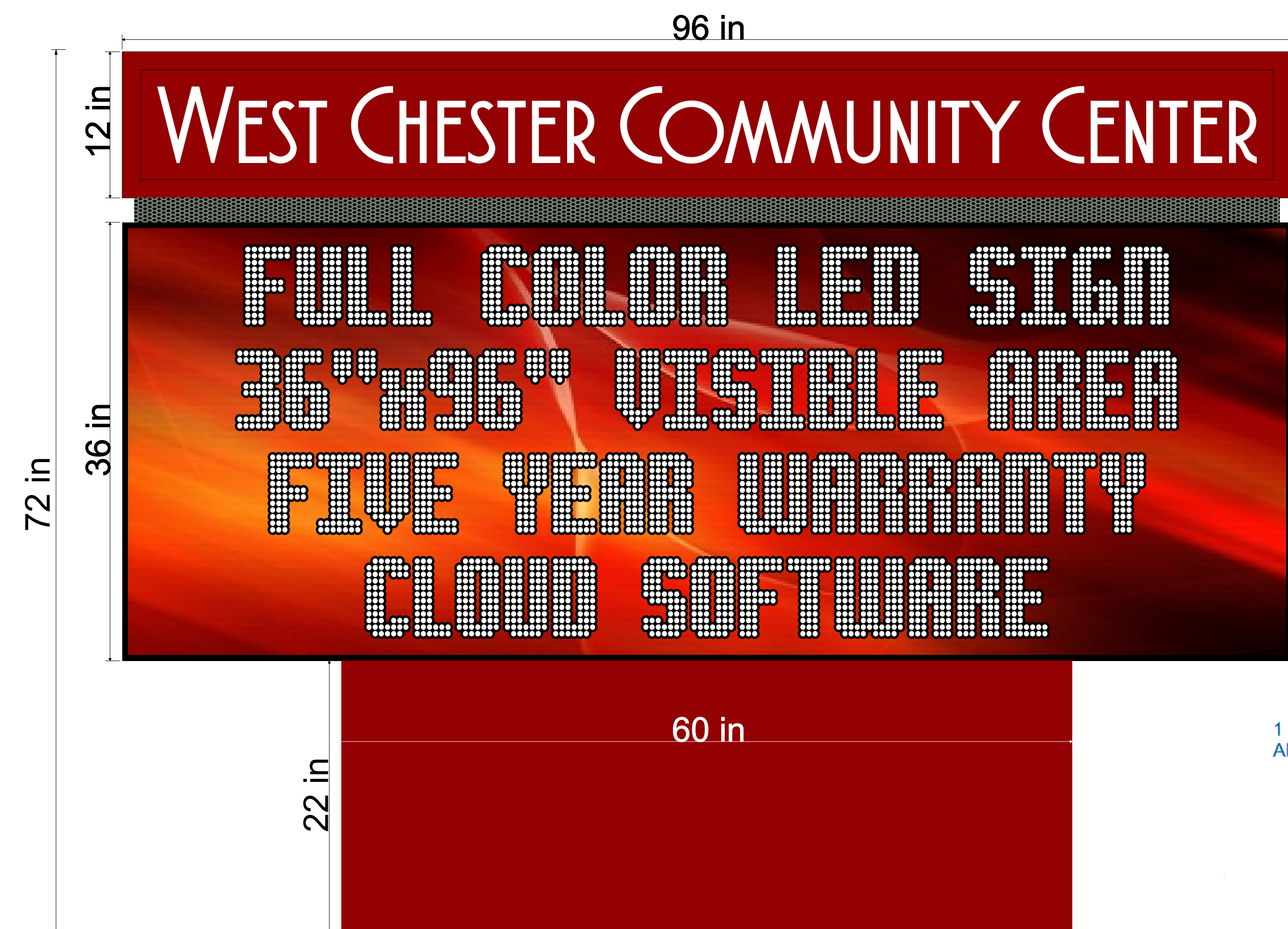

EXISTING



PROPOSED



<b>CUSTOMER NAME</b> Charles A. Melton Arts and Education	
<b>SITE ADDRESS</b> 501 East Miner Street West Chester, PA 19382	
<b>ORDER NUMBER</b> 081904	<b>PAGE NUMBER</b> 1

Sign Description:  
  
(1) 4' x 8' = 32 sq. ft. x 6' tall single-sided replacement ground sign to include a 24 sq. ft. LED message board

THIS IS AN ORIGINAL UNPUBLISHED DRAWING, CREATED BY KC SIGN CO. IT IS SUBMITTED FOR YOUR APPROVAL, IN CONNECTION WITH A PROJECT BEING PLANNED BY KC SIGN CO. IT IS FOR YOUR EXCLUSIVE USE, IT IS NOT TO BE USED, REPRODUCED, COPIED OR EXHIBITED IN ANY FASHION. THIS DRAWING IS PROPERTY OF KC SIGN CO.

<b>DATE</b> 1/17/25	<b>CONTACT</b> Greg Feld
<b>KC SIGN COMPANY</b> 142 Conchester Hwy Aston, PA 19014 Ph: 610-497-0111 Fax: 610-497-0110 E-mail - gfeld@kcsignco.com	

\*NOTE\* DUE TO VARIANCES AMONG COLOR PRINTED & COMPUTER MONITORS THE COLORS YOU SEE ON YOUR PROOF MAY NOT BE THE EXACT COLORS OF OUR PRODUCTS. THE COLORS YOU SEE SHOULD BE CONSIDERED CLOSE RENDITIONS TO THE ACTUAL COLORS AVAILABLE.





# INLAND DESIGN

Civil Engineers, Surveyors & Land Development Consultants

July 2, 2025

West Chester Borough  
Attn: Ramsey Reiner, Director of Building & Housing  
401 East Gay Street  
West Chester, PA 19380

**Re: Axle Square LLC, 210-214 West Washington St.  
Inland Design Project No. 12308  
Extension Letter**

Dear Ramsey:

On behalf of the applicant (Axle Square LLC) for the Axle Square Land Development project, I grant an extension to review the plan through the end of August 2025.

Sincerely,

Scott J. Zwizanski, P.E.  
Project Engineer