



HARB Meeting  
**September 25, 2025 @ 7:00 PM**  
*This meeting is recorded for public record.*

Carol Quigley, Chair
James Breen
Tom Clark
Matt Hazley
Joseph Martino
Marissa McCarthy
Dan Ritchie
Michael Wallacavage
Phillip Yocum
Thomas Dougherty, PC Liason

---

**HARB Meeting:**

- A. New Business
- B. Applications
  - 1. **2025-29- 225 E. Market St/Maureen Helms**  
*Proposed work: Sign*
  - 2. **2025-30 - 202 W. Gay St/Alonzo Adams**  
*Proposed work: Revised Sign Design*
  - 3. **2025-31 - 16 S. Church St/Victoria Pietrowski**  
*Proposed work: Sign*
- C. Discussion Items
  - 1. Approval of August 28, 2025 meeting minutes
- D. Other Business
- E. Adjournment

Visit [www.west-chester.com](http://www.west-chester.com) for access to all attachments.  
Agendas are posted to [www.west-chester.com](http://www.west-chester.com) by noon 3 business days prior to the meeting.

DATE APPLICATION RECEIVED: 09/15/2025

APPLICATION NUMBER: 2025-29

PROPERTY ADDRESS: 225 East Market St.

APPLICANT'S EMAIL: [REDACTED]

Note: All projects must have the appropriate sections completed in its entirety and attached to this form. *Only attach the applicable sections.* The application number will be assigned by the Building & Housing Department.

- 1) This application is for (check all appropriate boxes):
- Section #1 - Sign
  - Section #2 - Canopy or Awning
  - Section #3 - Repair, replacement or alteration from original  
(please supply photos or elevations of original)
  - Section #4 - Addition  
(supply architectural elevations and site drawings, as well as photos of the existing structure)
  - Section #5 - New Construction  
(supply architectural elevations and site drawings, as well as photos of buildings next to and around the site)
  - Section #6 - Demolition
- 2) Please indicate which items you are submitting with your application form. Do not submit originals, since they will be kept by the HARB for its official archives:
- Color or B/W Sketches
  - Old or Historic Photographs
  - Plot or Site Plans
  - Architectural Elevations
  - Photographs of the current existing site showing where changes are to be made, location of buildings and streetscape.

**All sketches, elevations, and plans must be signed by the preparer(s)**

The owner of this property and the applicant agree to conform to all applicable findings of the Borough of West Chester Historical and Architectural Review Board.

Applicant's name (print): Maureen N. Helms 8-26-25

Applicant's Signature: Maureen N. Helms Date: 8-26-25

Owner's Name (print): Steven Seymour

Owner's Signature: [Signature] Date: 8-5-25

**Note:** Check with the Building and Housing office of the Borough of West Chester to see if you need a building permit as well as a Certificate of Appropriateness **before** you begin your project

DATE APPLICATION RECEIVED: 09/15/2025  
APPLICATION NUMBER: 2025-29

**SECTION #1 - SIGNS**

(Attach a separate Section #1 for each of the signs you want to install)

**Instructions:** Provide color or black and white sketches of each sign and its message. Also show the proposed location and proportion to building façade. Attach photos of the streetscape and adjacent buildings.

Location of project: 225 East Market St.

Name of business: Wild Horse Salon

Applicant's name: Maureen W. Helms

Applicant's address: [REDACTED]

Applicant's phone number: [REDACTED] Applicant's email: [REDACTED]

Owner's name: Vanavard Real Estate Solutions LLC

Owner's address: [REDACTED]

Owner's telephone number: [REDACTED]

1) Are you replacing an existing sign? yes

2) How many signs do you wish to install? 1

3) On how many facades? 1  Front  Side  Back

4)  Hanging Sign  Building-mounted  Other

5) Give a thorough description of sign: Round wooden sign 2' Round w/ stacked text and bracket above the door, roughly 9' from bottom to the ground

6) Is there new illumination? Bracket Fixture Type? Bracket wooden  
How will it be mounted? Bracket

7) Sign Dimensions: Height: 2' x Width: 2' x Depth: 9'

8) If a hanging sign, what is the height from the sidewalk to the bottom of the sign? 9'  
(Borough Code requires 8'-0 minimum to bottom of sign)

9) How will this sign be mounted? Bracket  
(please note: any attachment to a masonry façade must be done through the mortar joints, NOT into the masonry).

10) If a hanging sign, describe the hanging bracket: metal

11) If a hanging sign, is this an existing bracket: No

12) Colors: metal bracket wooden sign

13) Message: Wild Horse Salon

14) Lettering style: please note that the historic preference is for any "serif" type: print

Please be sure to attach sample of sign wording in chosen lettering style

2412



2412

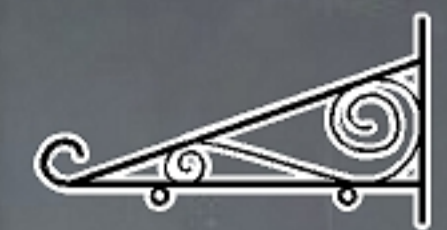

225



Main Contacts Contractors Submittals Details Workflow Fees Conditions Inspections Other Requirements Notes

Current processing time is 1 day (In review 1 day)

Project Name:  Add Note

Project Description:   
This is a design change from sign approved under HARB application #2025-21

Permit Number:	COA-25-0019	Applicant:	Alonzo Adams
Initial Application Number:	REFERENCE-25-0897	Primary Contact:	Alonzo Adams <span>?</span>
Permit Type:	CERTIFICATE OF APPROPRIATENESS- SIGNS	Primary Contractor:	Goshen Signs <span>?</span>
Status:	UNDER REVIEW <span>▼</span>	Last Activity:	09/15/2025 08:17
Process State:	Technically Complete	Last Inspection Date:	
Parent Permit:	<input type="text"/>	Initiated:	09/13/2025 <span>📅</span>
Assigned To:	User <span>▼</span> <input type="text"/>	Submitted:	09/13/2025 <span>📅</span> <span>🕒</span> Application is 3 days old
Fast Track:	<input type="checkbox"/>	Completed:	09/15/2025 <span>📅</span> <span>✅</span> 4 of 4 submittals received, 4 of 4 submittals accepted.
Applied for Online:	<input checked="" type="checkbox"/>	Approved:	<input type="text"/> <span>📅</span> <span>🗨️</span> 0 of 3 (0%) steps approved.
		Ready:	<input type="text"/> <span>📅</span> <span>✅</span> \$0.00 paid (100%), \$0.00 due.
		Issued:	<input type="text"/> <span>📅</span>
		Finalized:	<input type="text"/> <span>📅</span> <span>✅</span> No inspections.
		Closed:	<input type="text"/> <span>📅</span> <span>✅</span> \$0.00 deferred fees due.
		Expires:	03/14/2026 <span>📅</span> Exp Override: <input type="checkbox"/>

Site Address:  🔍 Verify Address and Coordinates

Site City:  Latitude:

State:  Site Zip:  Longitude:

**Contact** Phone Numbers Email Addresses Details Secure Details Points of Contact Portal Accounts



Replace Photo

Contractor:  Active:

First Name:  Middle Name:  Last Name:

Display Name:  ✎

Primary Phone:  Primary Email:

Portal Access Code:

---

















Mailing Address:  Edit Address

---

Physical Address:  Edit Address Copy Mailing Address

Save
Reset
Close
Delete
Audit
Convert to Contractor
Associations

Permit #: COA-25-0019	Status: UNDER REVIEW	Contact: Alonzo Adams	Site Address: 202 W GAY ST
Type: CERTIFICATE OF APPROPRIATENESS- SIGNS	Project Name: Halo Lit Sign	Contractor: Goshen Signs	WEST CHESTER, PA 19380

Name	Value
REASON FOR APPROPRIATENESS APPLICATION:*	Sign 
LOCATION OF PROJECT:*	202 W. Gay Street 
NAME OF BUSINESS:*	Revivea 
ARE YOU REPLACING AN EXSISTING SIGN:*	No 
HOW MANY SIGNS DO YOU WISH TO INSTALL:*	1 
HOW MANY FACADES WILL SIGN DISPLAY ON:*	Front 
HANGING SIGN:	No 
BUILDING MOUNTED:	Yes 
OTHER:	
IF OTHER PLEASE SPECIFY:	
GIVE A THOROUGH DESCRIPTION OF SIGN:	Metal Gold 
IS THERE NEW ILLUMINATION:	Yes 
FIXTURE TEXT:	Revivea 
SIGN DIMENSION HEIGHT:	10 
SIGN DIMENSION WIDTH:	84 
SIGN DIMENSION DEPTH:	

ORIGINAL SUBMISSION #2025-21

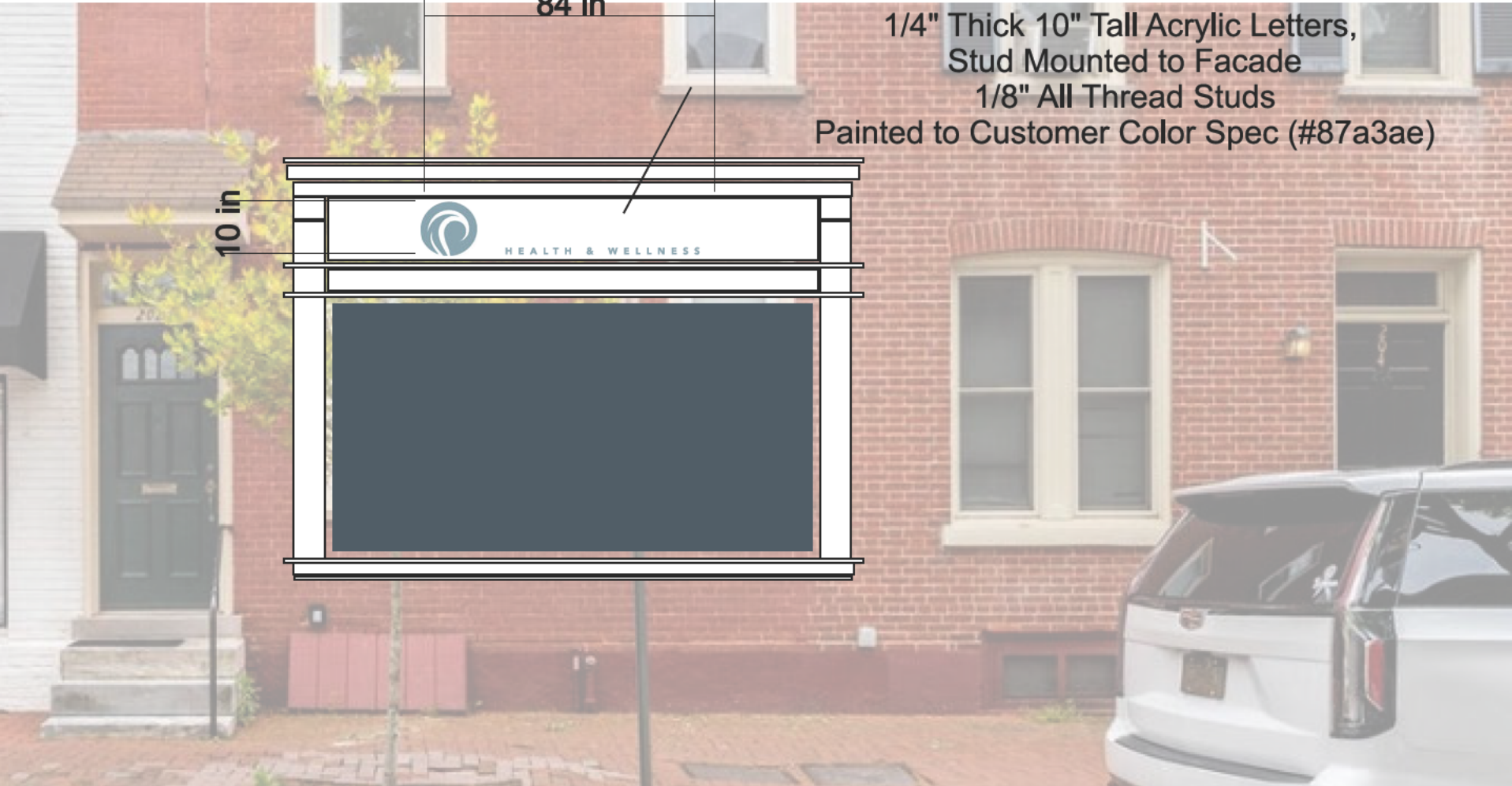

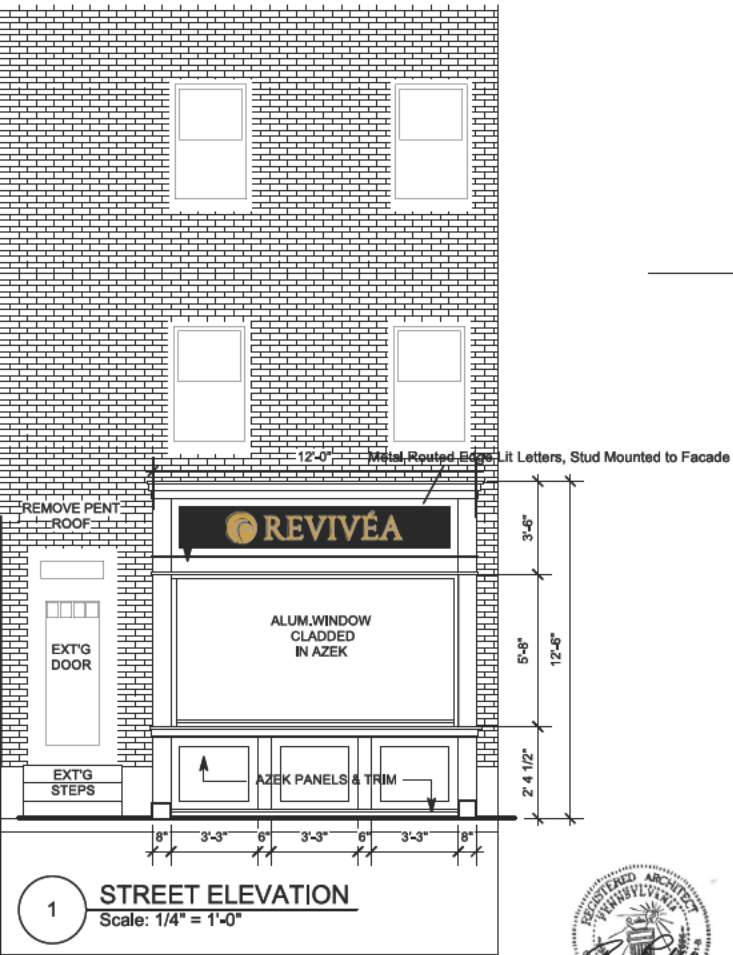

SK1 HARB 06 13 25



# Reverse Lit Channel Letter Diagram

## Spacer Mounted Halo lit channel letters

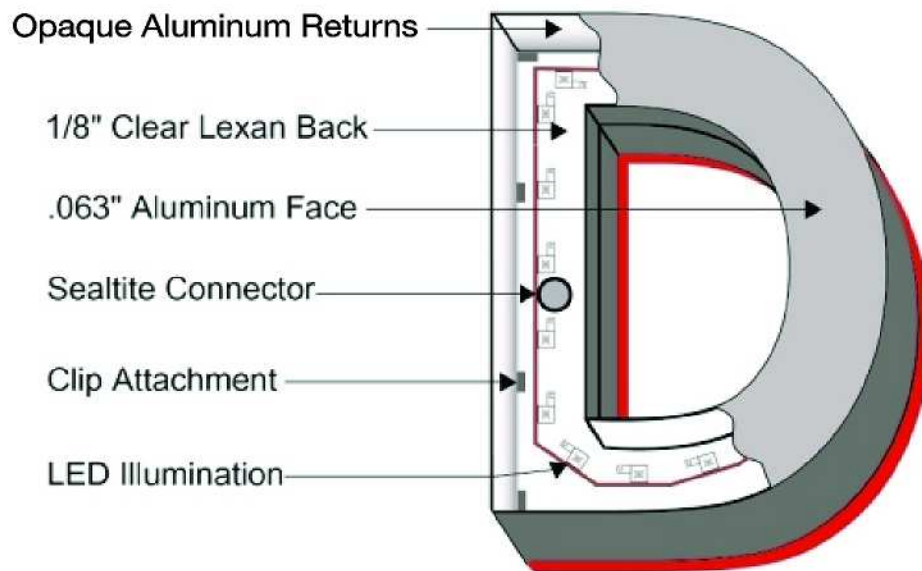

**FRONT VIEW**

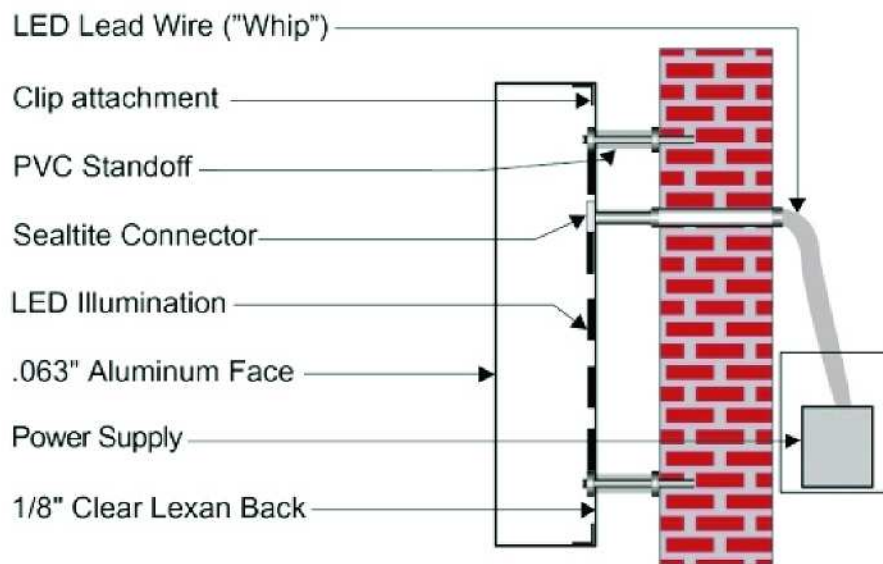

**SIDE VIEW**



202



202 Site/Grade

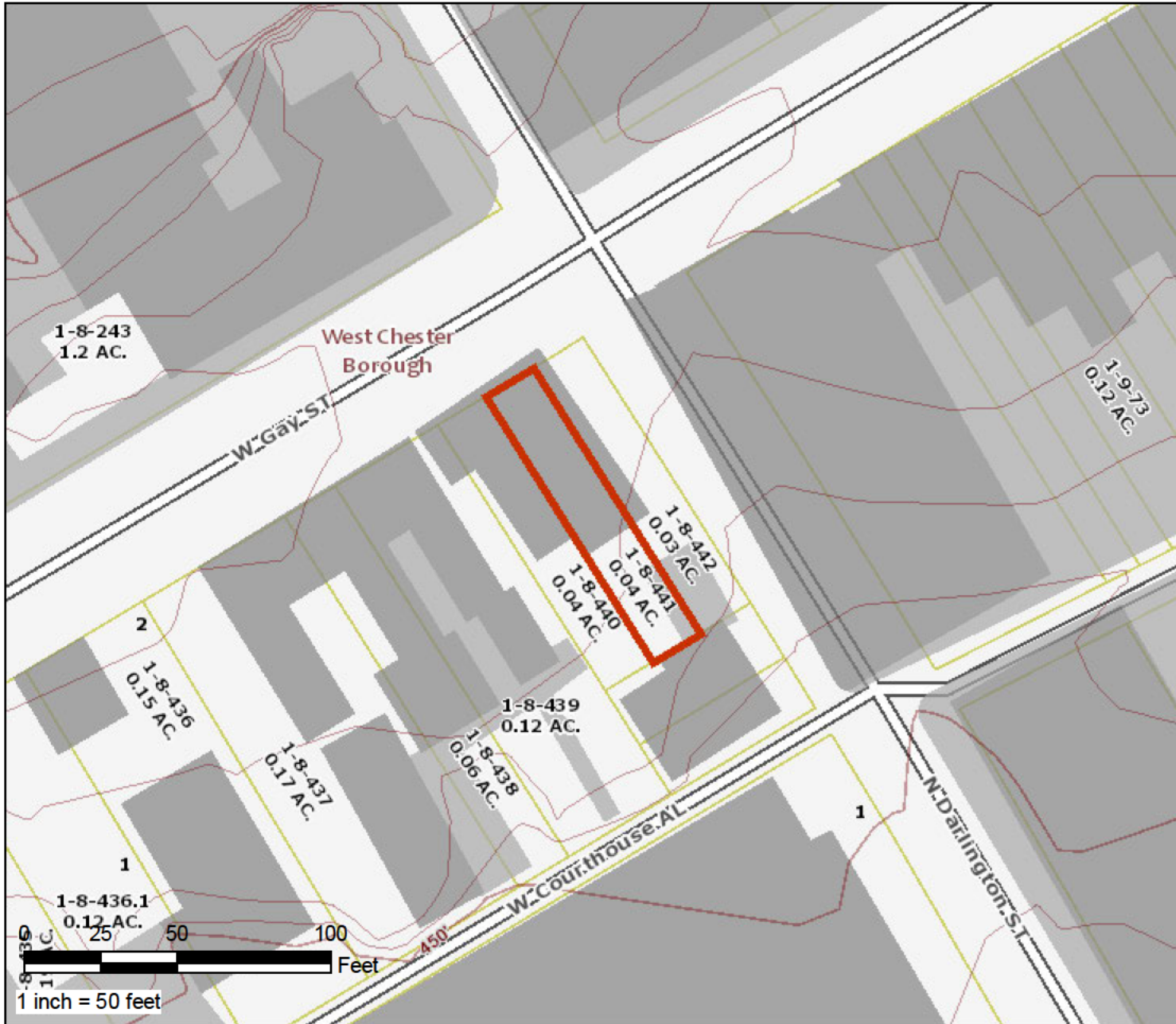

COUNTY OF CHESTER  
PENNSYLVANIA



Find Address Information

PARID: 0108 044 10000  
 UPI: 1-8-441  
 Owner1: UPTOWN VENTURE GROUP LLC  
 Owner2:  
 Mail Address 1: 18 WILSON AVE  
 Mail Address 2: WEST CHESTER PA  
 Mail Address 3:  
 ZIP Code: 19382  
 Deed Book: 11087  
 Deed Page: 890  
 Deed Recorded Date: 07/28/2023  
 Legal Desc 1: SS OF W GAY ST  
 Legal Desc 2: LOT & APTS  
 Acres: 0.0375  
 LUC: R-20  
 Lot Assessment: 30710  
 Property Assessment: 47820  
 Total Assessment: 78530  
 Assessment Date: 12/15/2023 7:39:35 AM  
 Property Address: 202 W GAY ST  
 Municipality: WEST CHESTER  
 School District: West Chester Area

Map Created:  
 Tuesday, March 19, 2024



County of Chester

**Limitations of Liability and Use:**  
 County of Chester, Pennsylvania makes no claims to the completeness, accuracy, or content of any data contained herein, and makes no representation of any kind, including, but not limited to, the warranties of merchantability or fitness for a particular use, nor are any such warranties to be implied or inferred with respect to the information or data furnished herein. For information on data sources visit the GIS Services page listed at [www.chesco.org/gis](http://www.chesco.org/gis).

Main Contacts Contractors Submittals Details Workflow Fees Conditions Inspections Other Requirements Notes

Application not yet complete

Project Name:  Add Note

Project Description:

Permit Number:	COA-25-0020	Applicant:	Piotrowski, Victoria
Initial Application Number:	REFERENCE-25-0906	Primary Contact:	Piotrowski, Victoria <span>i</span>
Permit Type:	CERTIFICATE OF APPROPRIATENESS- SIGNS	Primary Contractor:	
Status:	COMPLETENESS REVIEW	Last Activity:	09/15/2025 15:13
Process State:	Pending	Last Inspection Date:	
Parent Permit:	<input type="text"/>	Initiated:	09/15/2025 <span>📅</span>
Assigned To:	User <input type="text"/>	Submitted:	09/15/2025 <span>📅</span> <span>Application is 1 day old</span>
Fast Track:	<input type="checkbox"/>	Completed:	<input type="text"/> <span>📅</span> <span>4 of 4 submittals received, 3 of 4 submittals accepted.</span>
Applied for Online:	<input checked="" type="checkbox"/>	Approved:	<input type="text"/> <span>📅</span> <span>0 of 3 (0%) steps approved.</span>
		Ready:	<input type="text"/> <span>📅</span> <span>\$0.00 paid (100%), \$0.00 due.</span>
		Issued:	<input type="text"/> <span>📅</span>
		Finald:	<input type="text"/> <span>📅</span> <span>No inspections.</span>
		Closed:	<input type="text"/> <span>📅</span> <span>\$0.00 deferred fees due.</span>
		Expires:	03/14/2026 <span>📅</span> <span>Exp Override: <input type="checkbox"/></span>

Site Address

Site Address:  Verify Address and Coordinates

Site City:  Latitude:

State:  Site Zip:  Longitude:

Contact

Contact Phone Numbers Email Addresses Details Secure Details Points of Contact Portal Accounts

Contractor: No Active:

First Name:  Middle Name:  Last Name:

Display Name:  📌

Primary Phone:

Portal Access Code:

Mailing Address:

Edit Address

Physical Address:

Edit Address Copy Mailing Address

Save Reset Close Delete Audit Convert to Contractor Associations

Permit #: COA-25-0020	Status: COMPLETENESS REVIEW	Contact: Piotrowski, Victoria	Site Address: 16 S CHURCH ST
Type: CERTIFICATE OF APPROPRIATENESS- SIGNS	Project Name: Vera Studios	Contractor:	WEST CHESTER, PA 19382

Name	Value
REASON FOR APPROPRIATENESS APPLICATION:*	Sign
LOCATION OF PROJECT:*	16 S Church St
NAME OF BUSINESS:*	Vera Studios
ARE YOU REPLACING AN EXSISTING SIGN:*	Yes
HOW MANY SIGNS DO YOU WISH TO INSTALL:*	1
HOW MANY FACADES WILL SIGN DISPLAY ON:*	Front
HANGING SIGN:	Yes
BUILDING MOUNTED:	Yes
OTHER:	No
IF OTHER PLEASE SPECIFY:	
GIVE A THOROUGH DESCRIPTION OF SIGN:	Rectangular black sign with elegant white let
IS THERE NEW ILLUMINATION:	No
FIXTURE TEXT:	Vera Studios
SIGN DIMENSION HEIGHT:	20
SIGN DIMENSION WIDTH:	36
SIGN DIMENSION DEPTH:	1

VERA

STUDIOS





16 S Church St



© 2024 Google

© 2024 Google



© 2024 Google

tea by hesty  
WELLNESS & SPA

Jaffa  
DAY SPA





time by kristy

Day SPA

SOLUNA  
MASSAGE SPA  
OPEN NOW